

3.3 WH-SDC12K9E8 WH-UDZ12KE8

Item		Unit	Outdoor Unit		
Performance Test Condition			EN 14511 / EN14825		
Cooling Capacity	Condition (Ambient/Water)		A35W7		
	kW		10.70		
	BTU/h		36500		
	kcal/h		9200		
Cooling EER	W/W		2.68		
	kcal/hW		2.30		
Heating Capacity	Condition (Ambient/Water)		A7W35	A2W35	
	kW		12.10	11.50	
	BTU/h		41300	39240	
	kcal/h		10410	9890	
Heating COP	W/W		4.78	3.44	
	kcal/hW		4.11	2.96	
Heating ErP	Low Temperature Application (W35)		Warmer	Average	Colder
	Application	Climate			
	Pdesign	kW	9.0	12.0	11.0
	Tbivalent / TOL	°C	2 / 2	-10 / -10	-15 / -22
	SCOP / ns	(W/W) / %	6.47 / 256	4.58 / 180	4.31 / 169
	Annual Consumption	kWh	1859	5416	6289
	Class		A+++	A+++	A++
	Medium Temperature Application (W55)		Warmer	Average	Colder
	Application	Climate			
	Pdesign	kW	9.0	12.0	9.0
	Tbivalent / TOL	°C	2 / 2	-3 / -10	-15 / -22
	SCOP / ns	(W/W) / %	4.34 / 171	3.33 / 130	3.26 / 127
	Annual Consumption	kWh	2772	7453	6801
	Class		A+++	A++	A++
Noise Level	Condition (Ambient/Water)		A35W7	A7W35	A2W35
	dB (A)		Cooling: 50	Heating: 52	Heating: 52
	Power Level dB		Cooling: 68	Heating: 69 / 65	Heating: 69 / 65
Air Flow	m ³ /min (ft ³ /min)		Cooling: 94.6 (3340) Heating: 76.0 (2680)		
Refrigeration Control Device			Expansion Valve		
Refrigeration Oil	cm ³		FW50S (1300)		
Refrigerant (R32)	kg (oz)		1.60 (56.5) Precharge 2.20 (77.7) Maximum charge		
F-GAS	GWP		675		
	CO ₂ eq (ton) (Precharged / Maximum)		1.080 / 1.485		
Dimension	Height	mm (inch)	1340 (52-25/32)		
	Width	mm (inch)	900 (35-14/32)		
	Depth	mm (inch)	320 (11-24/32)		
Net Weight	kg (lbs)		90 (198)		
Pipe Diameter	Liquid	mm (inch)	6.35 (1/4)		
	Gas	mm (inch)	12.70 (1/2)		

Item		Unit	Outdoor Unit		
Standard Length		m (ft)	7 (23.0)		
Pipe Length Range		m (ft)	3 (9.8) ~ 30 (98.4)		
I/D & O/D Height Difference		m (ft)	20 (65.6)		
Additional Gas Amount		g/m (oz/ft)	30 (0.3)		
Refrigeration Charge Less		m (ft)	10 (32.8)		
Compressor	Type		Hermetic Motor		
	Motor Type		Synchronous Electric Motor (6-poles)		
	Rated Output	kW	3.00		
Fan	Type		Propeller Fan		
	Material		PP		
	Motor Type		DC (8-poles)		
	Input Power	W	-		
	Output Power	W	60		
	Fan Speed	rpm	Cooling: 680 (Top), 720 (Bottom) Heating: 490 (Top), 530 (Bottom)		
Heat Exchanger	Fin material		Aluminium (Pre Coat)		
	Fin Type		Corrugated Fin		
	Row × Stage × FPI		2 × 62 × 19		
	Size (W × H × L)	mm	903.7 × 1302 × 36.38		
Power Source (Phase, Voltage, Cycle)	∅		Three		
	V		400		
	Hz		50		
Input Power	Condition (Ambient/Water)		A35W7	A7W35	A2W35
	kW		Cooling: 4.00	Heating: 2.53	Heating: 3.34
Maximum Input Power For Heatpump System		kW	7.60		
Power Supply 1 : Phase (∅) / Max. Current (A) / Max. Input Power (W)			3∅ / 11.8 / 7.60k		
Power Supply 2 : Phase (∅) / Max. Current (A) / Max. Input Power (W)			3∅ / 13.0 / 9.00k		
Power Supply 3 : Phase (∅) / Max. Current (A) / Max. Input Power (W)			- / - / -		
Starting Current		A	4.0		
Running Current	Condition (Ambient/Water)		A35W7	A7W35	A2W35
	A		Cooling: 6.3	Heating: 4.0	Heating: 5.1
Maximum Current For Heatpump System		A	11.8		
Power Factor Power factor means total figure of compressor and outdoor fan motor.		%	Cooling: 92	Heating: 93	Heating: 95
Power Cord	Number of core		-		
	Length	m (ft)	-		
Thermostat			Electronic Control		
Protection Device			Electronic Control		

Item		Unit	Indoor Unit		
Performance Test Condition			EN 14511 / EN14825		
Operation Range	Outdoor Ambient	°C	Cooling: 10 / 43 ^{*1, *2} Heating: -25 / 35		
	Water Outlet	°C	Cooling: 5 / 20 ^{*1, *2} Heating: 20 / 55 (Below Ambient -15°C) ^{*3} 20 / 60 (Below Ambient -10°C) ^{*3}		
Internal Pressure Differential		kPa	Cooling: 42.0 Heating: 52.0		
Noise Level	Condition (Ambient/Water)		A35W7	A7W35	A2W35
	dB (A)		Cooling: 33	Heating: 33	Heating: 33
	Power Level dB		Cooling: 46	Heating: 46	Heating: 46
Dimension	Height	mm (inch)	892 (35-1/8)		
	Width	mm (inch)	500 (19-11/16)		
	Depth	mm (inch)	348 (13-23/32)		
Net Weight		kg (lbs)	41 (90)		
Refrigerant Pipe Diameter	Liquid	mm (inch)	6.35 (1/4)		
	Gas	mm (inch)	12.70 (1/2)		
Water Pipe Diameter	Inlet	mm (inch)	(1-1/4)		
	Outlet	mm (inch)	(1-1/4)		
Water Drain Hose Inner Diameter		mm (inch)	12 (17/36)		
Pump	Motor Type		Brushless DC Motor		
	No. of Speed		7 (Software Selection)		
	Input Power	W	145		
Hot Water Coil	Type		Brazed Plate		
	No. of Plates		36		
	Size (W × H × L)	mm	120 x 376 x 66		
	Water Flow Rate	l/min (m ³ /h)	Cooling: 30.7 (1.8) Heating: 34.4 (2.1)		
Pressure Relief Valve Water Circuit		kPa	Open: 300, Close: 210 and below		
Flow Sensor	Type		Piezoelectric sensor		
	Range	l/min	5 ~ 60		
Protection Device		A	Residual Current Circuit Breaker (25 ~ 40)		
Expansion Vessel	Volume	l	10		
	MWP	bar	3		
Capacity of Integrated Electric Heater		kW	9.00		

- Note:**
- In case it is necessary to indicate the air flow volume in (l/s), the value in (m³/min.) shall be multiplied by 16.7 and rounded down the decimal point.
 - If the EUROVENT Certified models can be operated under the “extra-low” temperature condition, -7°C DB and -8°C WB temperature with rated voltage 230V shall be used.
 - Capacity is measured at outdoor temperature 7°C DB and 6°C WB with controlled water inlet 30°C and water outlet 35°C (EN 14511-2)
 - Flowrate indicated are based on nominal capacity adjustment of leaving water temperature (LWT) 35°C and ΔT=5°C.
 - EER and COP classification is at 230V only in accordance with EU directive 2003/32/EC.
 - *** The sound pressure level is measured with distance 1.0m from the unit and height at 1.5m. (Test carry out for cooling at ambient 35°C DB and Water Out 7°C, heating at ambient 7°C DB / 6°C WB and water out 55°C)
 - **** The sound power level is measured with accordance to EN12102 under conditions of the EN14825.
- ^{*1} The system is locked to operate without COOL mode. It can be unlocked only by authorised installer or our authorised service partners.
- ^{*2} Only displayed when COOL mode is unlocked (This means when COOL mode is available).
- ^{*3} Between outdoor ambient -10°C and -15°C, the water outlet temperature gradually decreases from 60°C to 55°C.

5.1.7 Main Components

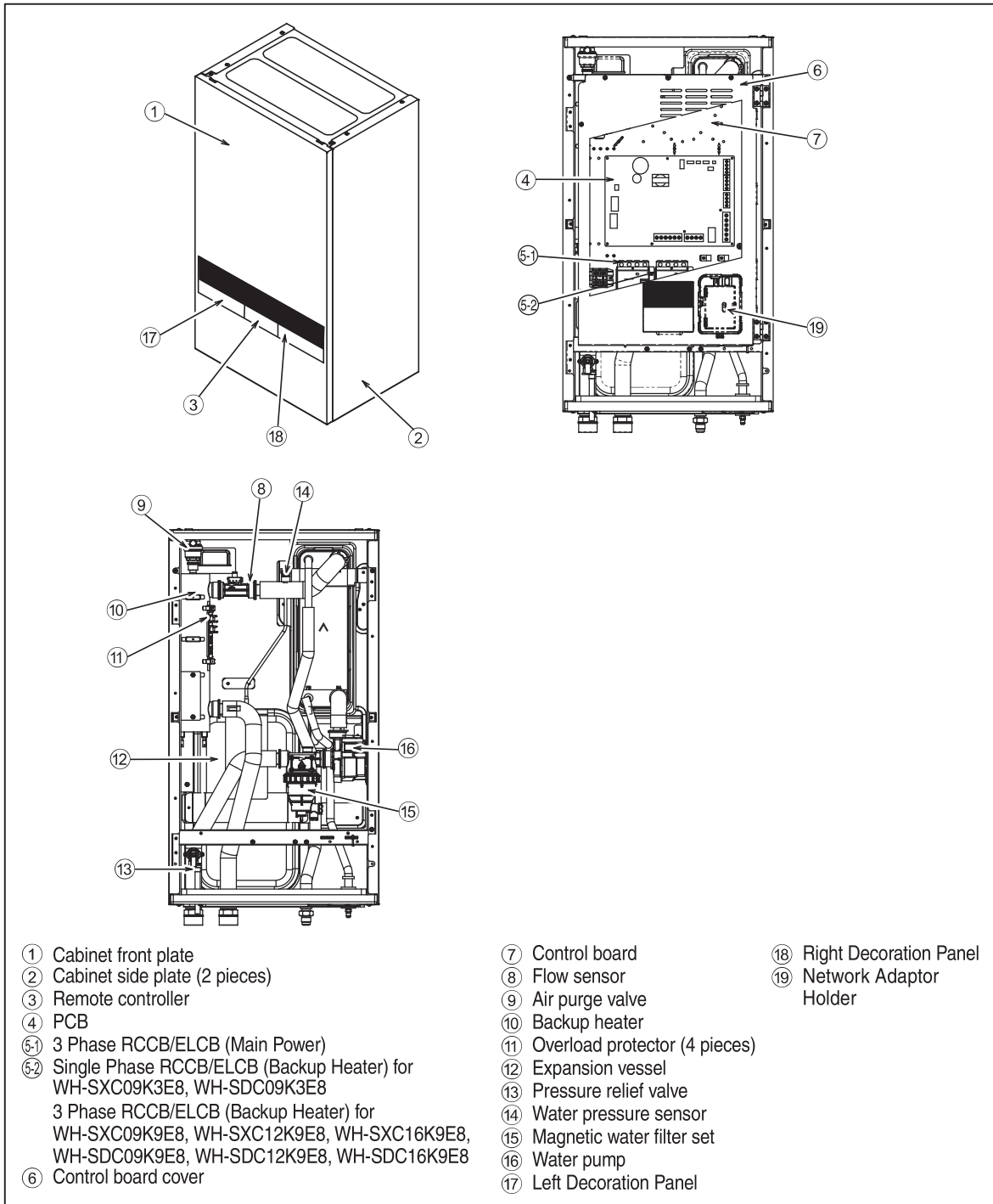

6. Dimensions

6.1 Indoor Unit

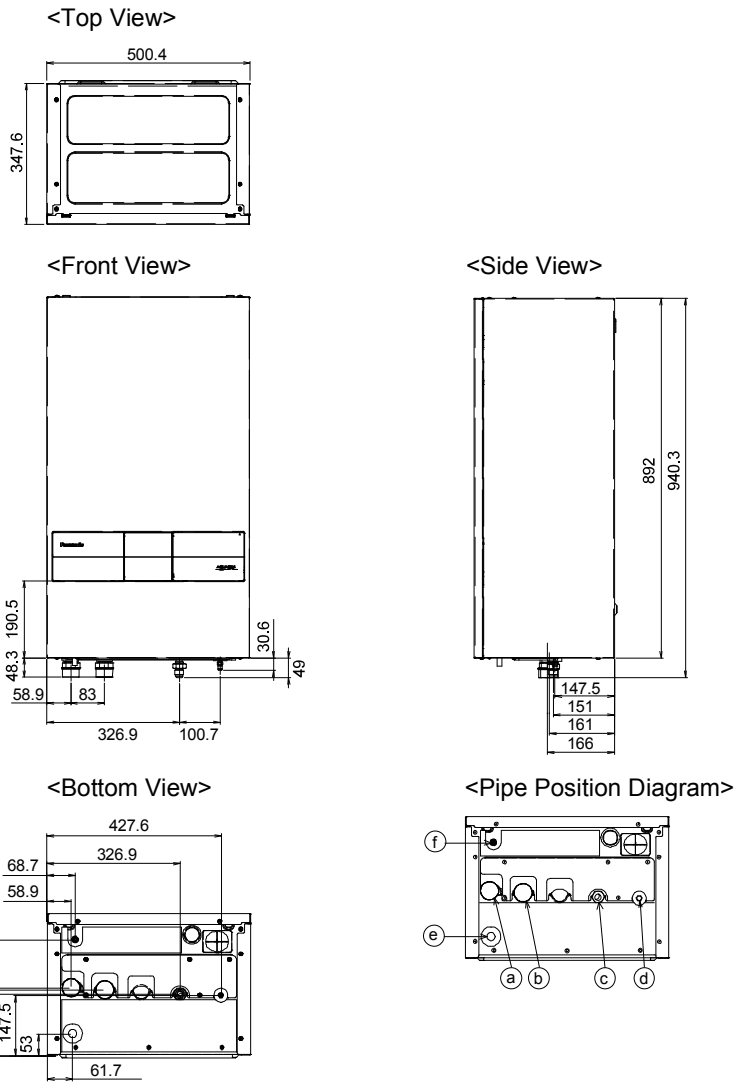

Letter	Pipe Description	Connection Size	
		WH-SDC**	WH-SXC**
Ⓐ	Water inlet	R 1¼"	R 1¼"
Ⓑ	Water outlet	R 1¼"	R 1¼"
Ⓒ	Refrigerant gas	7/8-14UNF	3/4-16UNF
Ⓓ	Refrigerant liquid	7/16-20UNF	7/16-20UNF
Ⓔ	Drain water hole	-	-
Ⓕ	Pressure relief valve drainage	3/8"	3/8"

Unit: mm

6.2 Outdoor Unit

<Top View>

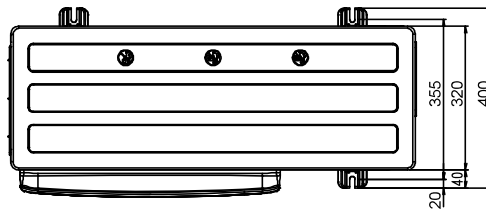

<Side view>

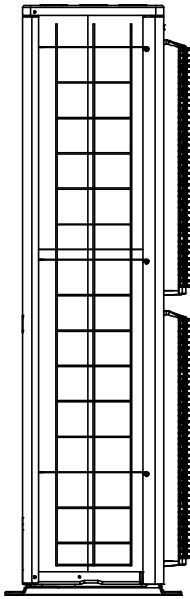

<Front View>

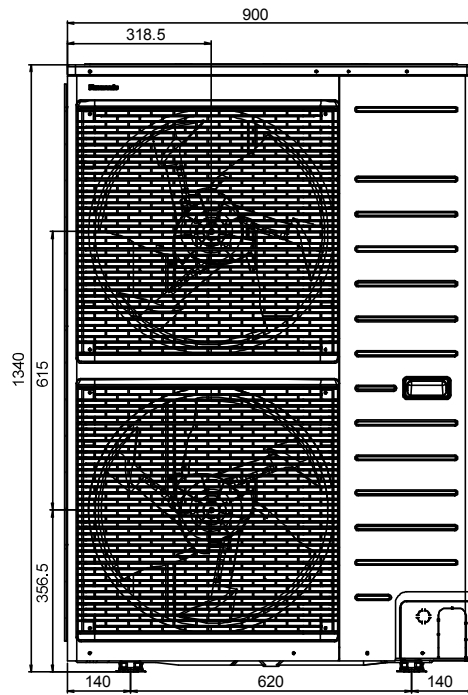

<Side View>

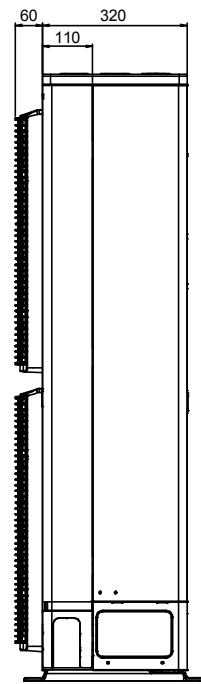

<Back view>

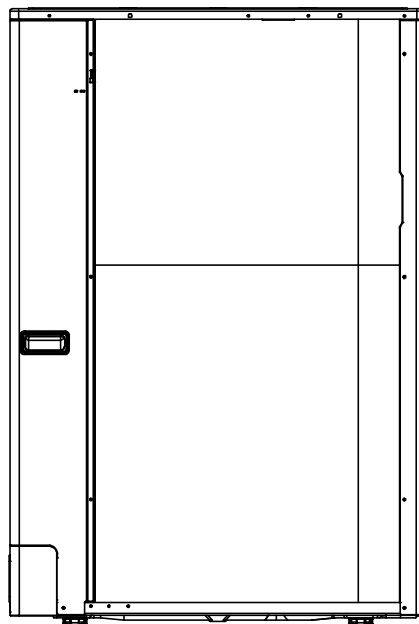

Unit: mm

7. Refrigeration and Water Cycle Diagram

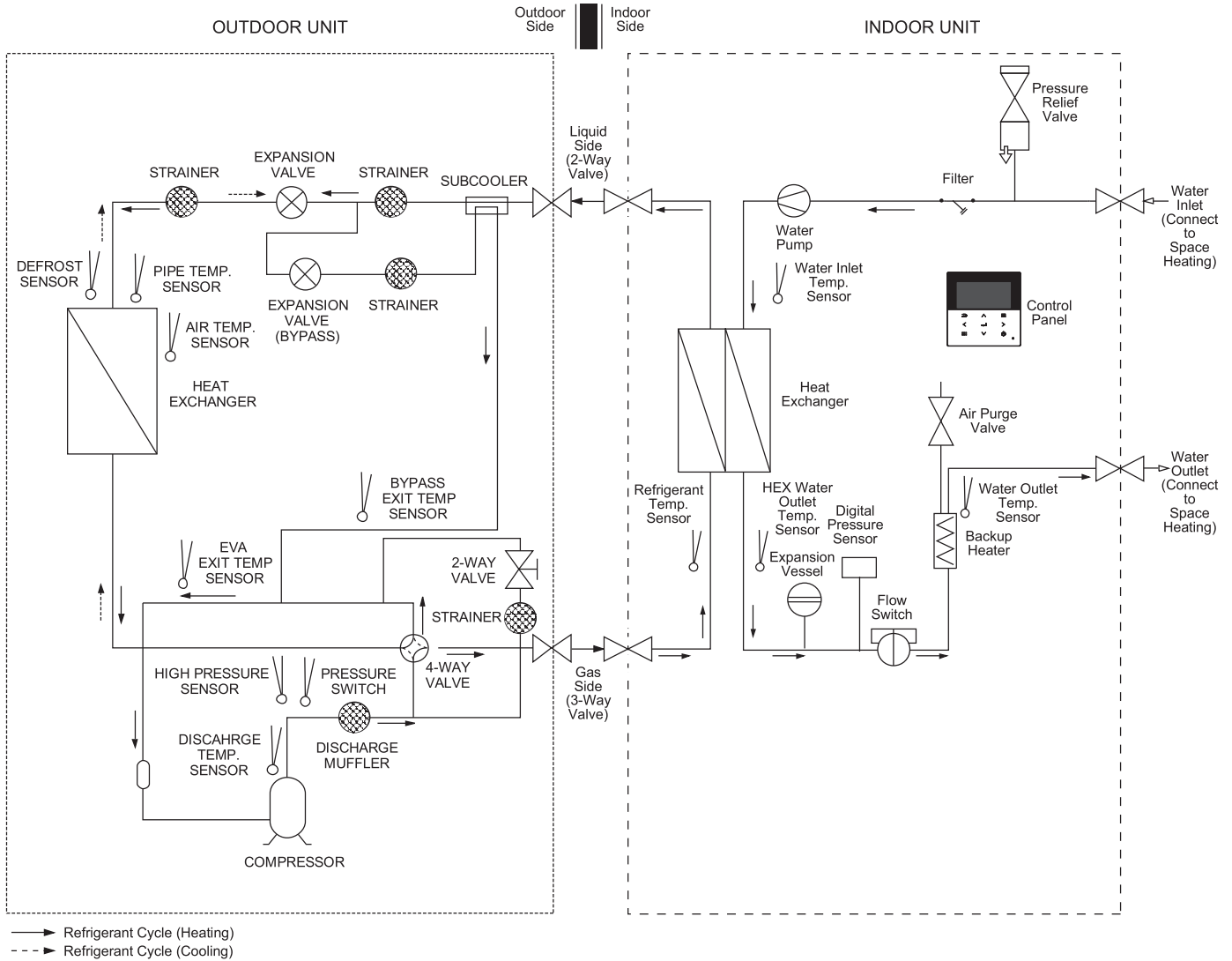

Model	Piping size		Rated Length (m)		Max Elevation (m)	Min. Piping Length (m)	Max. Piping Length (m)	Additional Refrigerant (g/m)
	Gas	Liquid	For Heat Pump Indoor Unit	For Hydromodule + Tank				
WH-UDZ09KE8*, WH-UDZ12KE8*	Ø12.7 mm (1/2")	Ø6.35 mm (1/4")	7	7	20	3	30	30
WH-UDZ16KE8*	Ø12.7 mm (1/2")	Ø6.35 mm (1/4")	5	5	20	3	30	30

Example: For WH-UDZ09KE8*

If piping length is 30m, the quantity of additional refrigerant should be 600g. [(30-10)m x 30 g/m = 600g]

20.1.2 WH-UDZ12KE8

Heating Characteristics at Different Outdoor Air Temperature

Condition

Outdoor air temperature : 7°C (DBT), 6°C (WBT)

Indoor water inlet temperature : 30°C

Indoor water outlet temperature : 35°C

Piping length : 7 m

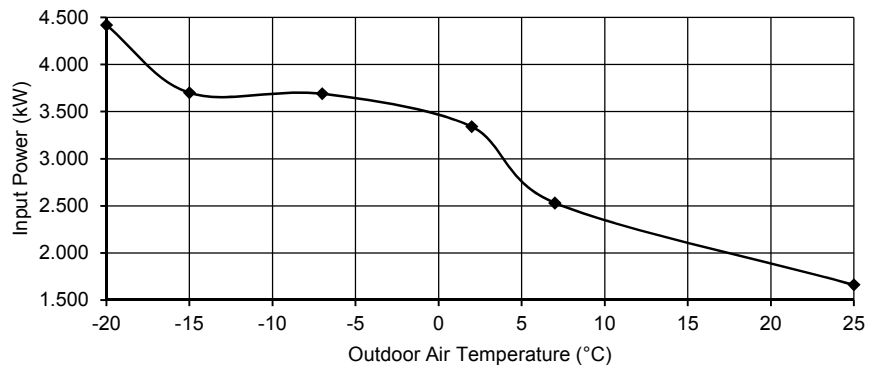
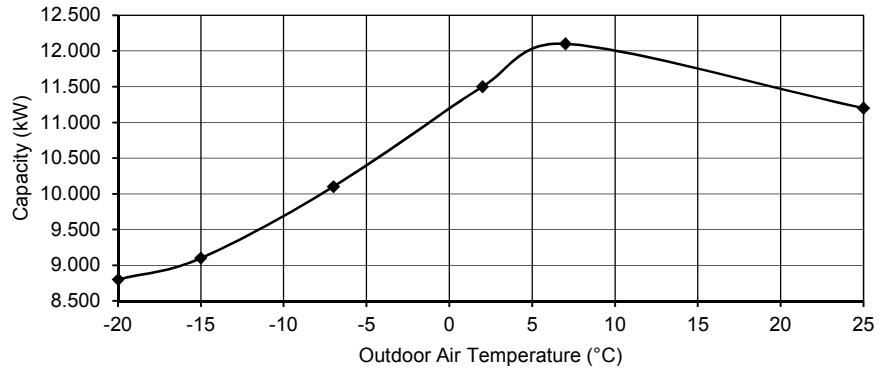

Cooling Characteristics at Different Outdoor Air Temperature

Condition

Outdoor air temperature : 35°C (DBT), -°C (WBT)

Indoor water inlet temperature : 12°C

Indoor water outlet temperature : 7°C

Piping length : 7 m

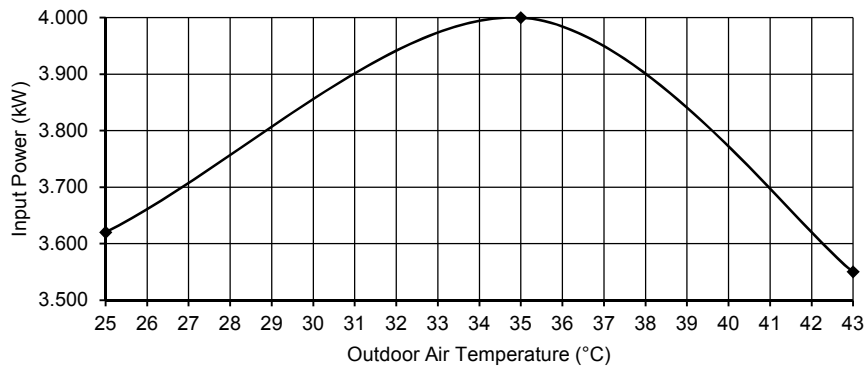
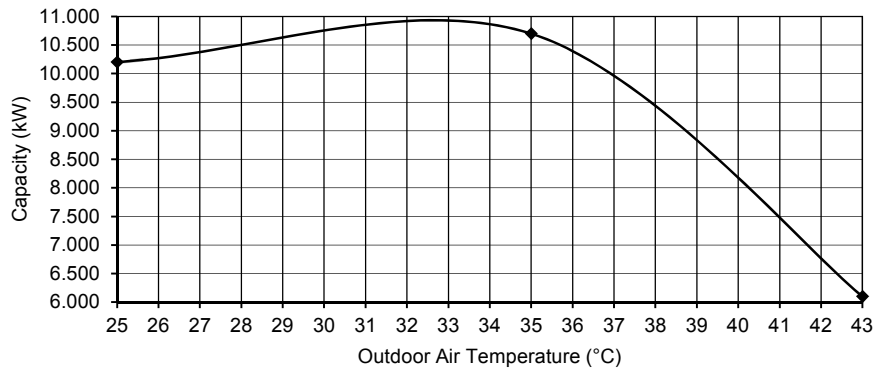

Cooling Characteristics at Different Outdoor Air Temperature

Condition

Outdoor air temperature : 35°C (DBT), -°C (WBT)

Indoor water inlet temperature : 19°C

Indoor water outlet temperature : 14°C

Piping length : 7 m

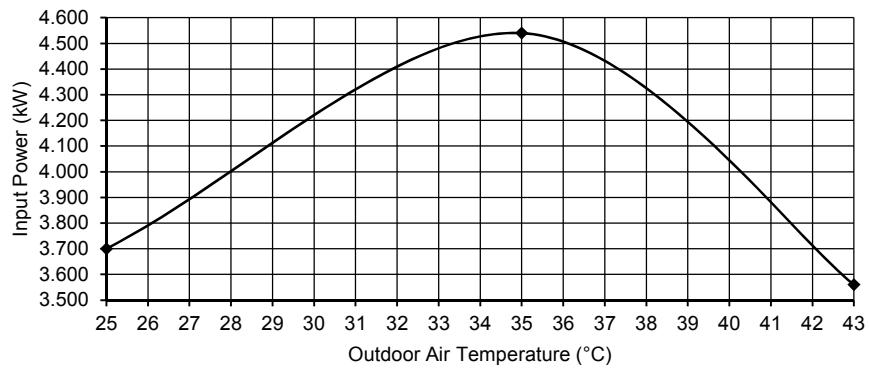
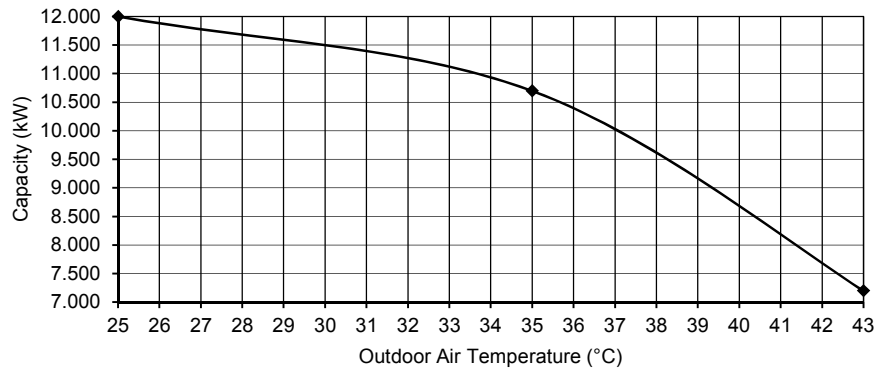

Cooling Characteristics at Different Outdoor Air Temperature

Condition

Outdoor air temperature : 35°C (DBT), -°C (WBT)

Indoor water inlet temperature : 23°C

Indoor water outlet temperature : 18°C

Piping length : 7 m

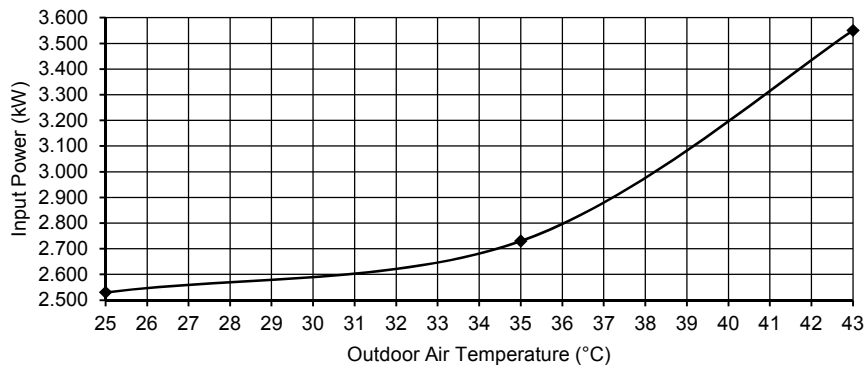
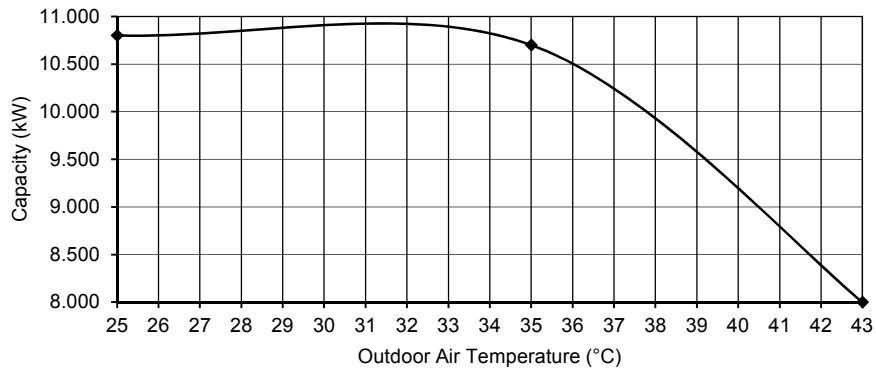

Heating Characteristics at Different Piping Length

Condition

Outdoor air temperature : 7°C (DBT), 6°C (WBT)

Indoor water inlet temperature : 30°C

Indoor water outlet temperature : 35°C

Piping length : 20 m / 30 m

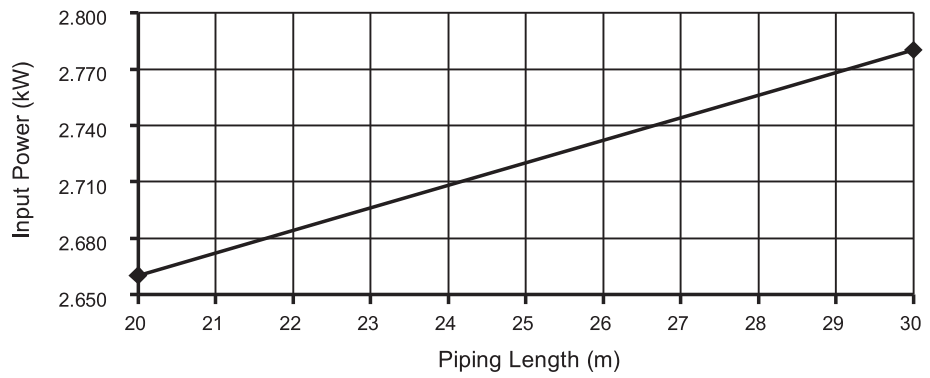
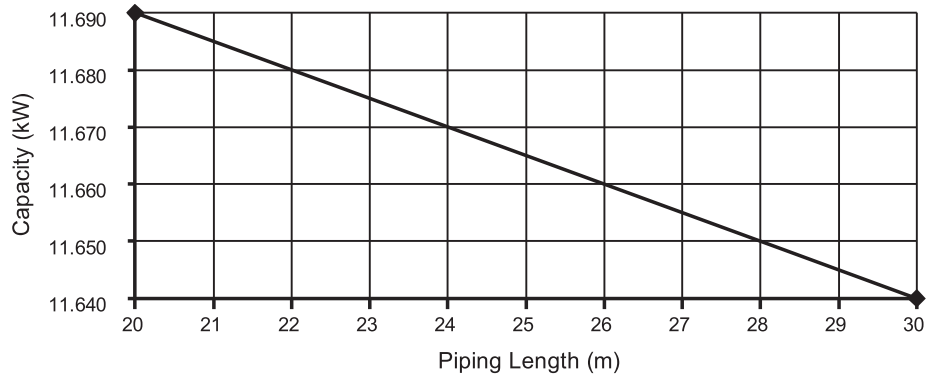

Cooling Characteristics at Different Piping Length

Condition

Outdoor air temperature : 35°C (DBT), -°C (WBT)

Indoor water inlet temperature : 12°C

Indoor water outlet temperature : 7°C

Piping length : 20 m / 30 m

