

目录

一、WHP11500AEDPC9EQ 规格书	1~4
1. 应用范围	
2. 压缩机规格	
3. 电机参数	
4. 一般特性	
5. 零件及图纸清单	
二、热泵热水器专用压缩机使用基准	5~15
三、验收依据及规则	16
1. 验收依据	
2. 验收规则	
四、图纸	17~30
五、修改经历	附页

SUBJECT

Model WHP11500AEDPC9EQ SPECIFICATION

WHP11500AEDPC9EQ 规格书

PAGE: 1/30

1. SCOPE 应用范围

This specification is applied to SHANGHAI HITACHI Heat pump water heater compressor.
此规格适用于上海日立电器有限公司生产的热泵热水器专用压缩机。

2. SPECIFICATION OF THE MODEL 压缩机的规格

项目 Item	规格 Spec
2.1 Model Type 型号	WHP11500AEDPC9EQ
2.2 Power source input to inverter 变频器外加电源	Rated voltage / Rated frequency/Phase 额定电压/额定频率/相数 380V/50Hz/3Φ OR 220V/50HZ/1Φ (内部试验用变频器输入电源, 仅供参考)
2.3 Output 输出功率	2950 (@3600 min ⁻¹)
2.4 Application 应用	Heat pump water heater 热泵热水器

2.5 Performance 性能参数

Item 项目	Standard Condition 标准工况	Rated Condition 额定工况
Rotational speed 转速	3400 min ⁻¹	3600 min ⁻¹
Nominal Heating Capacity 名义制热量	12650W	12670W
Motor input 电机输入功率	3080W	3170W
Current 电流	13.0A	13.0
COP(see*) 能效比(见*)	4.11	4.00
Test Conditions 测试条件		
Evaporating temp. 蒸发温度	10°C	7.2°C
Condensing temp. 冷凝温度	55°C	54.4°C
Liquid temp. entering expansion valve. 膨胀阀前液体温度	46.7°C	46.1°C
Return gas temp. 回气温度	20°C	35°C
Ambient temp. 周围温度	35°C	35°C
Wind speed 风速	2m/s	2m/s

SUBJECT

Model WHP11500AEDPC9EQ SPECIFICATION

WHP11500AEDPC9EQ 规格书

PAGE: 2/30

*. COP= $\frac{\text{Heating capacity}}{\text{Motor input}}$ 名义制热量 (W)

电机输入功率 (W)

*. Rated Capacity and input are measured with HITACHI inverter circuit by secondary Refrigerant calorimeter Methods of JIS B8606 by Shanghai Hitachi Electrical Appliances Co., Ltd.

Allowable capacity should be more than 95% of the rated capacity and allowable input should be less than 107% of rated motor input.

制冷能力和输入功率为用本公司专用变频器根据 JIS B8606 的第二制冷剂法测试。

允许制热量应为额定制热量的 95%以上, 允许电机输入功率为额定输入功率的 107%以下。

2.6 Refrigerant 制冷剂	R410A
2.7 Displacement 排气量	30.7 ml /rev
2.8 Allowable frequency range	900~7200 min ⁻¹
2.9 Oil 油	α 68HES-H or equivalent 1650±20ml
2.10 Allowable amount of refrigerant charge 制冷剂充注量	Below 4500g 4500g 以下
2.11 Compressor cooling 压缩机冷却	Forced air 强制空冷
2.12 Hermetic Terminal 密封接线柱	常规型
2.13 Space volume of inner case 壳体内容积	2628cm ³
2.14 Compressor weight 压缩机重量	19.10kg incl. Oil (包括油)
2.15 Motor Type 电机种类 Insulation class 绝缘等级	Direct current brushless motor 直流无刷电机 E class(级)
2.16 压缩机固有频率	19.9Hz/21.7Hz/24.5Hz (应尽量避免或者快速通过)

3. THE PARAMETER OF MOTOR 电机参数

项目 Item	参数 Spec	说明 explanation
3.1 Rotor Pole (Pole) 转子极数 (极)	4	---
3.2 Rated Frequency Range (Hz) 运行频率范围 (Hz)	30-240	Electrical Frequency, Relating to VDCmax of Inverter 电频率, 取决于驱动器 VDCmax
3.3 Demagnetizing Current (A) 永磁体减磁电流 (A)	54.01A	Peak Current, at 120°C, -5% Demagnetizing Rate 峰值电流, 120°C下测定, 通电时间 2 秒, 减磁率低于 5%

3.4 Inductance Ld (mH) d 轴电感 (mH)	Sheet 2 见表 2	---
3.5 Inductance Lq (mH) q 轴电感 (mH)	Sheet 2 见表 2	---
3.6 定子线圈电阻 (20°C) (Ω)	0.502 (20°C)	line-to-line 线间
3.7 Voltage Constant (Vrms/krpm) 感应电压常数 (Vrms/krpm)	43.10V/krpm	line-to-line 线间
3.7 Torque Constant (N·m/Arms) 电机转矩常数 (N·m/Arms)	0.69	Torque/Current 力矩/电流
3.9 Inertia (Kg·m ²) 转动惯量 (Kg·m ²)	0.000666	
3.10 Flux Φ _a (Wb) 磁通量 Φ _a (Wb)	0.1702	$\varphi \text{ (Per Phase, Peak)} = \frac{\sqrt{2} \times E0}{2\pi f \sqrt{3}}$ $\varphi \text{ (一相 peak 值)} = \frac{\sqrt{2} \times E0}{2\pi f \sqrt{3}}$
3.11 Magnet Material 电磁铁类型	NdFeB	

表 2

电流	1	2	3	4	5	6	7	8	9	10	11	12	13	14	15
q 轴	5.44	5.39	5.34	5.29	5.24	5.18	5.12	5.06	5.00	4.95	4.89	4.83	4.78	4.72	4.66
d 轴	3.71	3.65	3.65	3.64	3.63	3.61	3.59	3.56	3.54	3.51	3.48	3.45	3.42	3.39	3.36

4. CHARACTERISTICS 一般特性

4.1 Appearance 外观

The surface of the compressor is painted to black, without obvious flaw , impact scar, paint peel off, rust and so on.

压缩机的表面全部喷涂黑色油漆。外观上没有明显的伤痕、碰伤、剥落、生锈等现象。

4.2. Indication 表示

Compressor model type, manufacturing data are clearly indicated on the surface of compressor.

压缩机的表面注明压缩机的形式、制造年月日。

4.3. Residual moisture 残余水分含量 300mg MAX (以下)

4.4. Residual impurities 杂质含量 150mg MAX (以下)

4.5 Dielectric withstand 耐压特性

A 1500V alternating voltage for 1minute should be applied between live parts and dead metal parts.

通电部与非通电部之间，施加 1min 的 1500 V 交流电压，不破坏其绝缘。

	SUBJECT Model WHP11500AEDPC9EQ SPECIFICATION WHP11500AEDPC9EQ 规格书	PAGE: 4/30
--	---	------------

5 PARTS AND DRAWING LIST 零件及图纸清单

PARTS NAME 零件名称		QTY/SET 数量/套	DRAWING NO. 图纸号	PARTS NO. 部品号	REMARKS 备注
Compressor 压缩机		1	4CYCH0614	--	Dimensioned sketch 尺寸简图
Mounting Parts 安装件	Rubber grommet 橡胶避振脚	3	4CYC00643	3HNC00328A	
	Bolt 固定螺栓	--	4CYC00700	--	*
	Nut 固定螺母	--	M8	--	*
Electrical Parts 电器部品	Thermostat 热动开关	1	4CYC01036	RGNC0053	
	Terminal cover 接线盒盖	1	4CYC00988	3HNC0798A	
	Gasket 接线盒盖垫片	1	4CYC01047	3LNC00350A	
	Nut 固定螺母	1	3CYC00004	3YNC64230A	
	Rubber washer 固定垫圈	1	4CYC00174	3YNC64229A	
	Sleeve 螺杆护套	1	4CYC01042	3HNC00796A	
			4CYC01272		Lead routing 接线图 图 1 Pressure guarantee Chart 压力保证范围图 图 2 Oil level datum 油面基准图 图 3 Notes for rotational speed change 转速变化使用说明 Performance curve 性能曲线 Appendix 附录

*. Out of supply, for reference. 不提供, 仅供参考。

COMPRESSOR CRITERIA 压缩机使用基准

1 Strictly observe the specification 严格遵守规格书

The compressor should be used in specifications written in this “compressor specification” and not be used in specifications outside it.. The main circuit must link up with fuse or breaker.

本压缩机应在本规格书记载的规格内使用，不要在记载以外的规格中使用。对于主电路必须连接保险丝和断路器。

2 Source voltage 电源电压

Specified inverter is linked up with compressor terminals . Applied voltage of this inverter should be voltage specified in this “compressor specification”. Alternating voltage should never be applied on terminals (for example: commercial alternating voltage of 1 ϕ 100V, 200V, 3 ϕ 200V). This is because that if applied alternating current the direct current motor will demagnetize.

压缩机的端子间连接本压缩机专用的变频器，该变频器外加的电源电压应为压缩机规格中规定的电压。压缩机端子间绝对不能加交流电压（例如：工业交流 1 ϕ 100V, 200V, 3 ϕ 200V），这是因为一旦加了交流电，压缩机内的直流电机会退磁。

3 Operating voltage range 运转电压范围

The compressor should be operated in the range of rated voltage $\pm 10\%$, under standard condition and overload condition of rated frequency (applied voltage to inverter). It must be satisfied with item 5 , 6, 7.

在额定频率的标准条件下，额定电压的 $\pm 10\%$;过负荷条件下，额定电压的 $\pm 10\%$ 内使用。（变频器的外加电源）此时，必须满足 5, 6, 7 项的要求。

4 Operating temperatures and pressures 运行温度及压力

The operating temperatures and pressures of a compressor should be within the range shown in the table 2 and graph 1.

压缩机运行温度及压力应与表 2 和图 1 中所示规定相符。

5 Oil back and oil level 回油及油面

The oil should be returned continuously to the compressor and the structure of the refrigerating system should not make oil stay in the system. The oil level in compressor should be satisfied with chart 2. If not keep the oil level, the shortage will occur, and influence the reliability of the compressor. (please check the oil level in the compressor with the sight glass which supplied form SHEC.

压缩机应连续回油，制冷系统构造中不应有存油部分。且，压缩机内的油面高度应满足图 2 的条件。但是，当产生泡沫状态，液体变泡沫时，这部分不属于油面高度。假如不能满足油面高度，将造成滑动部分的供油不足，严重影响可靠性。（可以用观察油面用的带视镜的压缩机进行确认）。

Table 2 表 2

Item 项目	Operating Envelope 运行范围	
Discharge pressure 排气压力 MPa	4.762 MAX 以下 (condensing temperature 冷凝温度:70℃)	(see graph 1) (见图 1)
Suction Pressure 吸气压力 MPa	0.272~1.652 (Evaporation Temperature 蒸发温度: -30℃~25℃) It can also be 0.101~ 0.272 MPa when in transition , but should not be used when it is less than 0.101MPa 过渡时可在 0.101~ 0.272 MPa, 不应在不满 0.101MPa 的条件时使用。	
Compressor case bottom temp 壳体底部温度	99°C or below and 6 degrees higher than condensing temperature 99℃或更低并比冷凝温度高 6℃	
Motor winding temp 电机线圈温度	Rated voltage: 额定电压时: 105℃以下 MAX	R. Voltage±10%: 额定电压±10%时 120℃以下 MAX
Accumulator temp 储液器温度	Higher than outlet pipe of evaporator 比蒸发器出口高	
Ambient temp 环境温度	Meet for the condition of above mentioned motor winding temp. 能满足电机线圈温度的条件即可	

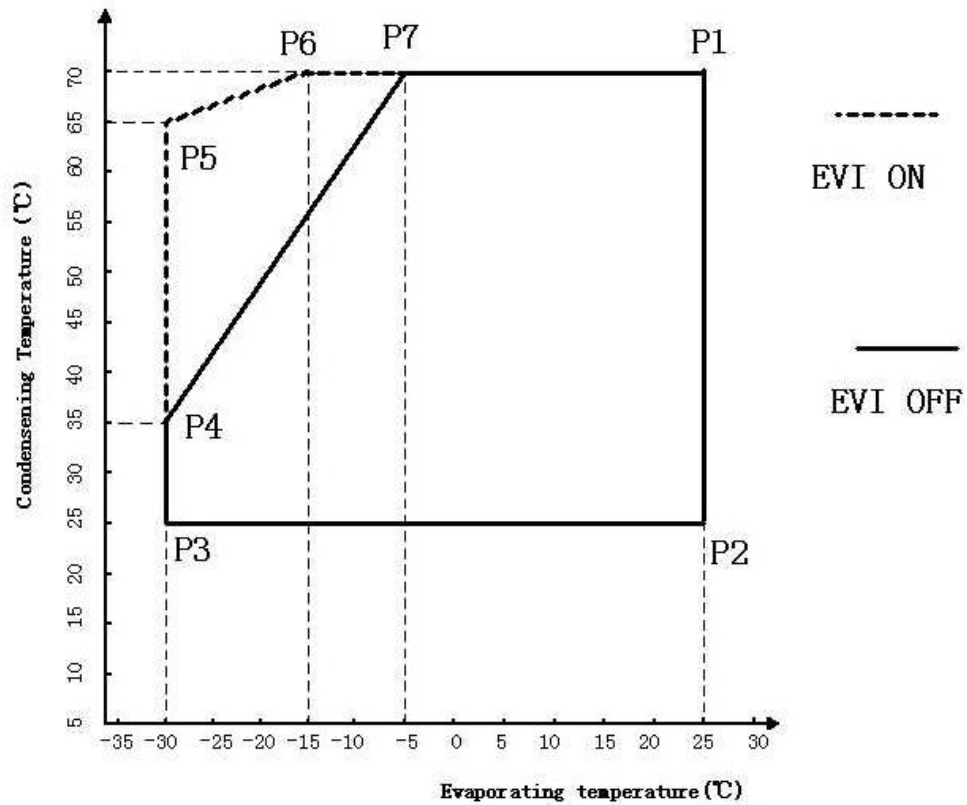

Graph 1 图 1

	P1	P2	P3	P4	P5	P6	P7
Condensing temperature 冷凝温度	70°C	25°C	25°C	35°C	65°C	70°C	70°C
Evaporation Temperature 蒸发温度	25°C	25°C	-30°C	-30°C	-30°C	-15°C	-5°C

6 Current limitation 电流的限制

Current peak among motor terminals (include instantaneous current peak) should be below demagnetizing current in order to prevent magnet in motor from demagnetization.
电机端子间的电流峰值（包含瞬时峰值）在减磁电流以下，这是为了防止电机内的永久磁体退磁。

7 Pressure difference between suction and discharge 吸气、排气压力差

In all allowable rotational speed range, the difference of pressure should be more than 0.39MPa{4kgf/cm²}. But if there is no problem of noise when assembled in air conditioner, it can also below this value.

在可使用的转速全范围内，压力差在 0.39MPa{4kgf/cm²} 以上。但是，组装在产品上未发生噪音问题时，也可在该数值以下。

8 Discharge pipe temperature 排气管温度

Discharge pipe temperature is measured at a distance 300mm from the surface of compressor and should be less than 110°C. The tip of the thermocouple is fixed by soldering when measuring discharge pipe temperature .Furthermore, soldering point is covered with urethane foam to prevent the effect of wind.

排气管的温度是在距离压缩机表面 300mm 的位置测定, 应在 110°C 以下。而且, 测量排气管温度时热电偶的前端用锡焊固定, 并且为了防止送风的影响, 用氨基甲酸乙酯泡沫塑料罩住锡焊的部位。

9 Dust of compressor hermetic terminals 压缩机密封接线柱的灰尘

Compressor hermetic terminals should be mounted with specified cover in right way to prevent dust entering, and should be used in direction which dust is hard to enter in.

为防止灰尘进入, 压缩机的密封接线柱应按指定的方法安装指定的防护罩, 应在灰尘不易进入的方向使用。

10 Lead wire of compressor hermetic terminals 压缩机密封接线柱部的导线

Measuring the temperature of hermetic terminals , lead wire should be resist to the temperature and be clamped so as not in touch with the surface of compressor and pipe.

测量压缩机密封接线柱部的温度, 应使用能耐其温度的导线。固定导线使其不与压缩机表面及配管接触。

11 Start-stop frequency 起动、停止的频度

The frequency should be less than 6 times per hour. Operating time from start to stop should be more than 3 minutes. Stopping time should be more than 3minutes.

1 小时在 6 次以下, 从再次起动到下一次停止为止运转时间在 3 分钟以上, 停止时间 3 分钟以上。

12 Rate of rotational speed change 压缩机的转速变化率

The rate of compressor rotational speed (acceleration) should be less than 133min⁻¹/s, But if The variable range is below 120min⁻¹, rate can also be less than 600min⁻¹ when rotational speed is reduced to avoid temporary over- current.

压缩机的转速变化率(加速比率)应在 133min⁻¹/s 以下。但是当为了防止电流的瞬间过载而降低转速时, 转速的可变幅只要在 120min⁻¹ 以下, 转速变化率允许在 600min⁻¹ 为止。

13 Air and moisture in refrigerating system 制冷系统中的空气和水分

The degree of vacuum in refrigerating system should be less than 20Pa (150×10⁻³mmHg) at room temperature just before charging refrigerant. The quantity of water should be less than 0.15ml.

制冷系统的真空度, 在常温、制冷剂充注前应为 20Pa (150×10⁻³mmHg) 以下。含水量应在 0.15ml 以下。

14 Impurities in refrigerating system 制冷系统中的杂质

(1) The weight of residue on the inside surface of the heat exchanger and tube should be less than $0.01\text{g}/\text{m}^2$. But metallic dust should not be permitted in the system. This value means the weight of foreign residue collected by filter paper after washing inside surface of the heat exchanger tubes with R-11.

附着在热交换器、配管内侧表面杂质量应为 $0.01\text{g}/\text{m}^2$ 以下。但是，不允许含有金属粉。该数值是用 R-11 洗净热交换器管道表面后用滤纸收集到的杂质量。

(2) Prevent the impurities from entering into the enclosed unit system used R410A. When the impurities entered into the enclosed system, it will damage the moving mechanism parts and result in the capillary depositing.

应当避免垃圾等进入系统。当使用 R410A 冷媒的系统里混入了较多的垃圾等杂质时，将成为促使压缩机的滑动部件发生损伤和毛细管堵塞的原因。

(3) Eliminate all system contaminants such as trichlorethylene, alkalies, soaps, oil, acids & washing fluid used at machining heat exchanger and tubes.

清洗所有在加工热交换器管道时残留的污物如三氯乙烯、酸、碱、肥皂液、油和清洗液等。

15 Compressor vacuum operation 压缩机的真空运转

Compressor should never be operated while under vacuum. Otherwise, internal arcing can cause damaging parts.

压缩机绝对不能在真空状态运转，否则压缩机内部易产生电弧放电导致损坏内部零件。

16 The compressor should be operated for more than 20 seconds within 15 minutes after charging refrigerant into the system so proper lubrication results.

在充注制冷剂之后的 15 分钟内，压缩机必须运转 20 秒以上，以保证适当的润滑。

17 Liquid refrigerant return limitations 有关液体制冷剂回流的限制项目

(1) Liquid refrigerant level in s-tank should be lower than the top of s-pipe in s-tank. (see chart at right)

储液器内的液面应比储液器内 S 管的前端位置低。(参照右图)

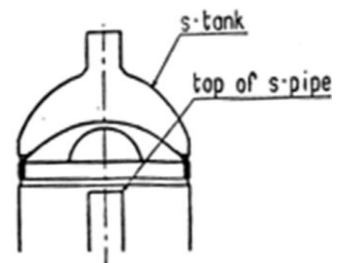

(2) There should not exist noise of the liquid refrigerant compression, current and vibrancy increase. System can append the assistant stank or reduce the amount of refrigerant to prevent from liquid refrigerant compression. Refrigerant system forbid liquid refrigerant from flowing back compressor in any case. In normal condition the overheat gas refrigerant should flow back compressor.

无液压缩音、电流增加、振动增加等情况发生。为了防止液压缩，可以追加辅助储液器或减少冷媒封入量。无论在何种条件下，制冷系统都不应有液体向压缩机回流。在正常运转条件下，应有过热气体向压缩机回流。

18 Purge parts with dry nitrogen or dry air to remove remains in parts (dust, detergent, etc.) before assembly of system. Time for purging: over one second for pipe; over three seconds for heat exchanger. Purging pressure: 0.9 ± 0.1 MpaG. Dew point of dry air: Below -20°C .

为把部品内的残留物（灰尘、清洗剂等）除去，在组装系统部品前，要用干燥氮气或干燥空气吹净部品。吹的时间：管件要在1秒以上，热交换器在3秒以上。吹气压力：0.9MpaG，干燥空气露点： -20°C 以下。

The motor winding temperature should be less than 149°C and hermetic terminal body temperature should be less than 177°C in process of manufacturing.

制冷系统制造过程中，电机的卷线温度应在 149°C 以下。且密封接线柱本体的温度应在 177°C 以下。

19 Apply for vehicle 车辆等的装载

The compressor should not be used on moving equipment such as automobiles, trains, ships, etc.

压缩机不能用在汽车、铁路、船舶等移动物体上。

20 Installation 安装方式

The rotational axis of compressor should be kept vertical during operation. But in actual application the axis incline must be within 5° at all directions during operation.

压缩机的旋转轴应保证在垂直方向运转，但是实际应用时在各方向倾斜 5° 以内使用。

21 Pipe vibration 管道振动

The displacement of the pipes, which connect from the compressor to other parts of the refrigerate-or systems, should be less than 0.8mm ($1/32''$) when the compressor is operating at allowable rotational speed range and voltage range of rated $\pm 10\%$.

Displacement in excess of 0.8mm ($1/32''$) will require changing tube length and/or routing.

如压缩机在转速允许范围内及额定电压的 $\pm 10\%$ 的范围内运转，连接压缩机及制冷系统部的管道的位移小于 0.8mm ($1/32''$)，上述位移超过 0.8mm ，则应该改变管子的长度或路径。

22 Connecting tube design

In designing and routing tubing that connect from the compressor to the other parts of the air conditioner, following should be considered.

Moving tubes to the moving parts; minimum clearance 12.7mm(1/2")

Moving tubes to non-moving parts; minimum clearance 9.5mm((3/8")

Moving tubes never touch to lead wire.

在设计及考虑连接压缩机及空调机其它部件的管子路径时，应考虑以下各因素：

移动管道至移动部件：最小间隙 12.7mm(1/2")

移动管道至非移动部件：最小间隙 9.5mm(3/8")

移动管道不得与引线接触。

23 Avoid refrigerant migration 避免冷媒迁移

The refrigerant migration to compressor shell should be avoided during the heat pump water heater system shut down periods, It's suggested that the electric heating belt should be used around the shell bottom when necessary.

热泵热水器系统在停机过程中应避免冷媒迁移至压缩机壳体中，必要时建议在压缩机壳体底部增加电加热带。

24 Miscellany 其他

(1) The compressor should be carried carefully to avoid drop, drag, impact and should not apply partial force on projection parts such as pipe, hermetic terminals, foot during carrying and processing.

小心搬运，防止在搬运、作业中落下、拖拉、冲击及在管子、密封接线柱、底脚等凸出部施加局部力。

(2) The compressor should not be operated to form a vacuum and to absorb air. The compressor only can run in one direction which according to lead routing wiring diagram. Never reversion otherwise the compressor will be in trouble.

压缩机不得自身抽真空、空运转。压缩机只能按一个方向运转，所以必须按照接线图所示接线。逆转时压缩机会发生故障，所以要绝对禁止。

(3) The compressor should not be left opened in the atmosphere for more than 5 minutes.

压缩机不得在空气中持续打开 5 分钟以上。

When the air entered into the unit system with refrigerant R410A, it will expedite the deterioration of the oil and result in the capillary depositing and the reducing of insulation resistance.

应避免空气进入系统，当使用 R410A 冷媒的系统里面混入过多的空气时，将促使冷冻机油分解和劣化，从而成为毛细管堵塞和压缩机绝缘不良的原因。

(4) Electric pulse should not be applied to compressor when it is in vacuum.

压缩机内部处于真空状态时，不得加电脉冲。

(5) The compressor should be kept in the place with low-dust, low-moisture.

压缩机应保存在灰尘少、湿气少的环境中。

- (6) The compressor can't be used in the place with corrosive atmosphere such as hot spring and chemical warehouse. It should not be the structure often splash water on the surface of the compressor forcibly.
- 压缩机不能在温泉、化学品仓库等有腐蚀性气体环境中使用。制冷系统不应是强制地经常向压缩机表面浇水的构造。
- (7) The trouble of cross valve, electromagnetic valve, defroster, refrigerant controller, fan motor used in refrigerating system may cause compressor accident. So their reliability should be ensured completely. Moreover, the way of design, manufacture, application of refrigeration cycle with less-leak should be adopted.
- 制冷系统使用的四通阀、电磁阀、除霜装置、冷媒控制器、风扇电机等的故障会引起压缩机事故。所以应充分保证这些零部件的可靠性。同时, 采用泄漏少的设计、制造、使用方法。
- (8) The main electric circuit should be equipped with fuse or breaker.
- 主电路必须连接保险丝或断路器。
- (9) Refrigerant should be charged from the end of condenser of refrigerating systems. Never Charge refrigerant to the compressor directly.
- 制冷剂应从制冷系统冷凝器的尾端注入, 而不能直接注入压缩机。
- The refrigerant should always be charged in liquid state. When the refrigerant is charged in gas state. The percent component will possibly be changed.
- 冷媒应该在液体状态下进行充填, 在气体状态时进行充填时冷媒的组分将发生变化。
- (10) Temperatures within systems during stable compressor operation should not be less than -35°C to prevent wax precipitation from the oil.
- 系统内温度在压缩机稳定运行时, 不应低于 -35°C 以防止油中蜡的成分沉淀。
- (11) The units of refrigerating system should be connected to earth.
- 制冷系统装置应接地。
- (12) Compressor mounting 压缩机防振构造
- Rubber grommets are designed soft to provide the noise isolation and to lessen vibration Energy transmission. Stud bolt should be designed to provide sufficient clearance for noise and vibration isolation and to prevent compressor from coming off its mount.
- 橡胶避振脚是采用防止由于噪音引起的振动及振动能量吸收原理设计的。所设计的固定杆应提供足够的间隙用于噪音及振动隔离, 并且防止压缩机从避振脚上滑落。
- (13) There should be adequate clearance between the under-surface of Push-Nut and the upper surface of rubber grommets.
- 在卡圈下表面与橡胶避振脚的上表面之间应保留足够的间隙。

- (14) SHEC will not take any responsibility against accident that is caused by the accessories equipped by yourselves.
关于客户自己配备的压缩机附件(例如热敏电阻等)的事故, 与上海日立电器有限公司无关。
- (15) The hermetic terminals of compressor should not be inserted slantingly and not be applied twisting force after inserting so as to avoid reducing of terminal fixed force.
压缩机的密封接线柱端子与空调器的端子连接时, 不得斜插或插入后不得施加扭曲力等以免降低端子固定力。
- (16) The pipe and hermetic pens attached to the compressor should not be bent.
与压缩机连接的管道及密封接线柱销子不得弯曲。
- (17) The dropped compressor can't be used anymore.
跌落的压缩机不能再使用。
- (18) Compressor can be used when ambient temperature is higher than -10°C . Confirm the start-up of compressor if the temperature of compressor surface is below -10°C . Heat up compressor to reach the temperature higher than -10°C with heater if the ambient temperature is below -10°C .
环境温度在 -10°C 以上时, 压缩机可以使用。当压缩机表面温度低于 -10°C 时, 要确认压缩机的启动情况。如果环境温度低于 -10°C , 用加热器将压缩机加热到 -10°C 以上再启动也可以。
- (19) Set a thermistor on the case cover of compressor to prevent from accident of leakage of refrigerant.
The thermistor can stop the operation of compressor when compressor in abnormal temperature.
The lead wires of thermostat is enveloped with tube, as same as that of the terminals, to avoid direct contact with the compressor and pipe.
为了防止由于冷媒泄漏引起的事故, 在压缩机头部放置热动开关, 异常高温时通过电器品动作, 使压缩机停止运转。热动开关的引出线与连接接线端子的引出线相同, 外面用套管包住, 不能直接接触压缩机及配管。
- (20) The compressor should not be splashed with water intentionally. Prevent moisture from entering into the enclosed unit system. When the moisture entered into the unit of the refrigerant R410A, the refrigerant oil and the organic compound material presented in the hermetic motor will possibly decompose on the affecting of water. It will result in the capillary depositing and the reducing of insulation resistance.
不得有水溅入压缩机。应避免水分进入系统。当使用 R410A 冷媒的系统里面混入过多的水分时, 冷冻机油和压缩机电机中使用的有机材料在水分的作用下将发生水解, 从而导致毛细管堵塞、压缩机绝缘不良。

It is necessary to install a dryer to dehumidify the residual moisture mixed in the refrigerant in the cycling system. The specially defined molecular-sieve dryer is advised.

为除去残存在系统中并与冷媒一起循环的水分，有必要安装一个除去系统中水分用的干燥器。
请使用指定的分子筛。

- (21) Use the refrigerant of specified brand. When the refrigerant not specified used, it will possibly cause trouble of the performance and reliability of the compressor by the impurities in the refrigerant.

请使用指定的冷媒。当使用指定以外的冷媒时，会因不纯物较多而影响压缩机的性能和可靠性。

- (22) The lead wires should be connected to hermetic terminals without being touched on the surface of the compressor.

引线连接至密封接线柱时，不得与压缩机表面相接触。

- (23) Be careful of avoiding oxide scale while soldering during assembly of refrigerating system.

(for example: flow or fulfill dry nitrogen)

在组装制冷系统时，若采用钎焊应考虑防止氧化皮的产生。(例如在充满干燥氮气的气氛下作业)

- (24) The quantity and kind of contamination (the process materials) in the cycle should be grasped and managed. Carry on reliability test that input contamination a lot than anticipated contamination quantity.

在制冷循环中必须控制和掌握污染物（生产辅料）以及垃圾的量。并增加系统中比预期设定多的污垢物含量进行可靠性使用。

- (25) To avoid water and impurity into he refrigeration system and make sure no leakage of refrigerant during the operating course. It's required to direct the erector and maintenance man .

对于实施安装、维修等作业的服务人员，要求对其进行指导和教育，在相关作业时，必须确保制冷系统中不能进入水分、异物，必须确认无冷媒泄漏。

- (26) The start-up current and torsion of compressor 压缩机启动电流及扭矩

Adjust the start-up current of the compressor to get enough torsion by inverter. Confirm and measure the start-up current if change the parts and design.

通过调整变频器的启动电流，保证足够的输出力矩。部品结构或设计变更后一定要测定启动电流，确认没有问题。

(27) The fuse or/and breaker should be equipped in the main circuit.

保险丝、断路器应配备在主电路中。

(28) The thickness of the refrigerating system using tube 制冷系统配管的壁厚
 the tube thickness as followed 制冷系统使用的铜管壁厚如下表所示

external diameter(mm) 外径(mm)	6.35	9.52	12.7	15.88	19.05	22.2	25.4	31.75	38.1	44.45
Thickness (mm) 壁厚 (mm)	0.8	0.8	0.8	1	1	1	1	1.1	1.4	1.5

1. Basis for Checking upon Delivery 验收依据

The Performance test will be carried out in accordance with this "compressor Specification".
The Safety Performance in accordance with GB4706.1 Safety of household and similar electrical appliances General requirements and GB 4706.17 Safety of household and similar electrical appliances Particular requirements for motor-compressor.

性能试验方法按本仕様书中有关内容执行。

安全性能按 GB4706.1 家用和类似用途电器的安全通用要求及 GB4706.17 家用和类似用途电器的安全电动机—压缩机的特殊要求。

2. Rule for Checking upon Delivery 验收规则

If come across any quality problem, please notify the company in written form within 30 days after the arrival of the cargo, the company shall exchange exactly the number of the products, otherwise they shall be regarded as being up to standard.

若发现质量问题，请在到货后 30 天内向本公司提出书面通知，经确认确属本公司责任，本公司将如数掉换，否则将作自然合格。

4CYC00700

版本标识 A

记号	来历	年月日	订正	审查	记号	来历	年月日	订正	审查
①					④				
②					⑤				
③					⑥				

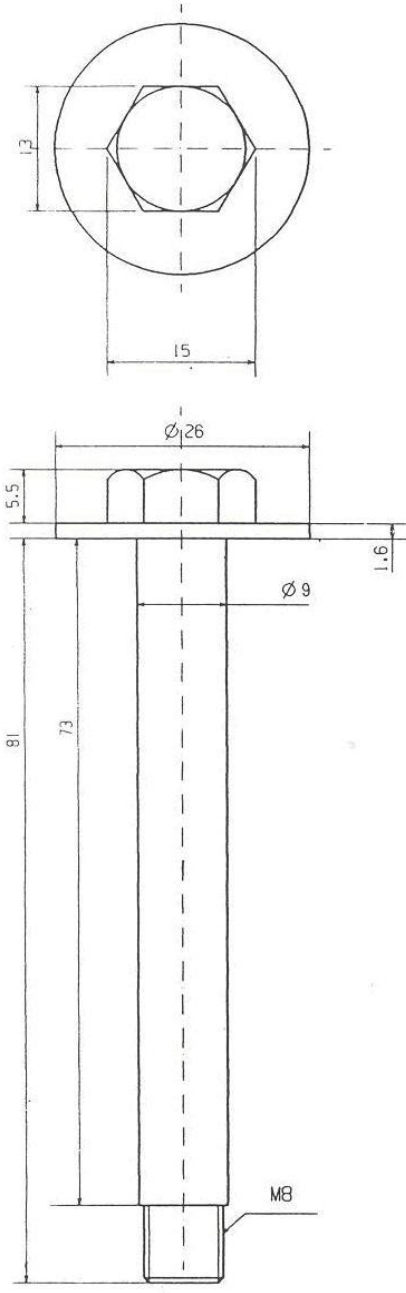

注记
表面处理：电镀

	RE-MARKS		PROJECTION	SCALE	
				NTS	
REGD.	DWN. 张夕菲 00.08.14	TITLE BOLT	Shanghai Hitachi, Ltd.	DWN. NO. 4CYC00700	
	CHKD. 周易 00.05.14				
	CHKD.				
	APPD. 肖峰 00.10.8				

记号	来历	年月日	订正	审查	记号	来历	年月日	订正	审查
①	设计	2012.7.17	程永生	谢飞	①				
②					②				
③					③				

4CYC01036
版本标识 B

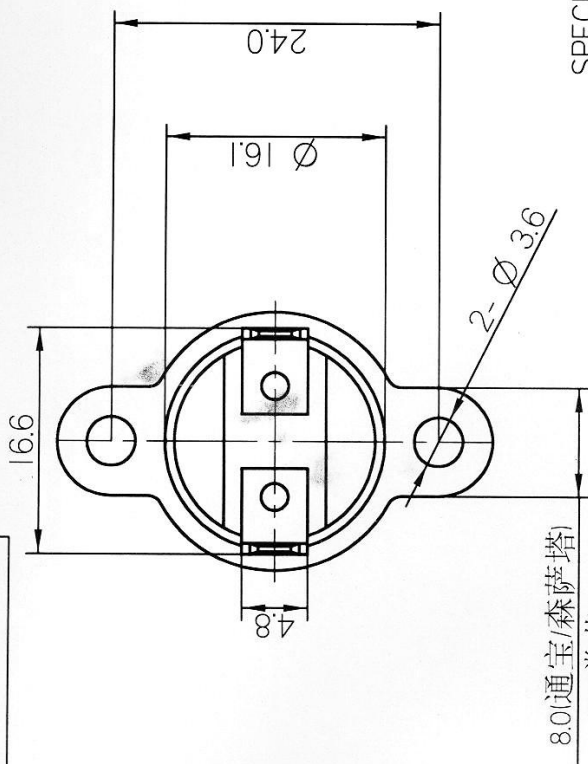

8.0(通宝/森萨塔)
6.5(常荣)

SPECIFIED LIMITS
规格值

厂家	部品号	动作温度(OFF)	动作温度(ON)	测定电压	测定电流
通宝	KSD301 KSD301-11.5/108C22520-S2	115±3°C	95±5°C	AC250V	10A
森萨塔	INT01L-6785	115±3°C	95±5°C	AC125V	15A
常荣	HPC-115/95-UI	115±3°C	95±5°C	AC250V	10A

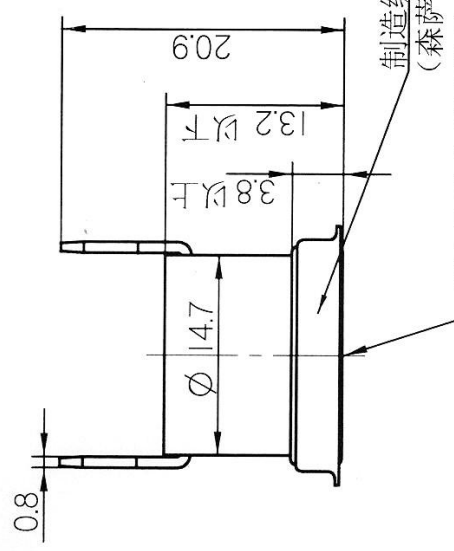

部品号/动作温度代号
(通宝、常荣)

REGD	RE. MARKS	PROJECTION	SCALE
		shangjia Hitachi, Ltd.	NTS
DWN. DWG. 2012.6.8	TITLE	THERMOSTAT	
CHKD. 程永生 2012.6.8		DWG. NO. 4CYC01036	
APPD. 程永生 2012.6.8			

记号	来历	年月日	订正	审查	记号	来历	年月日	订正	审查
①					④				
②					⑤				
③					⑥				

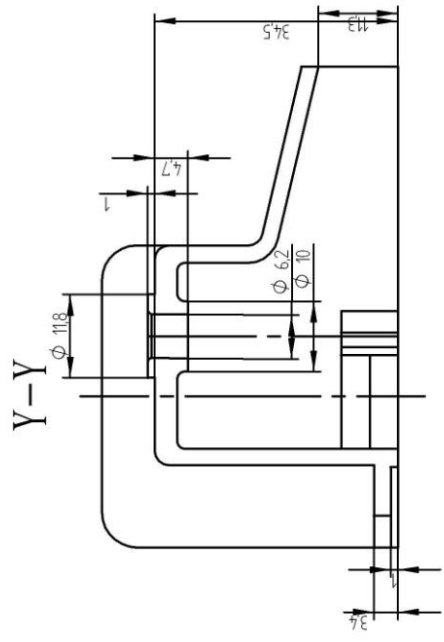
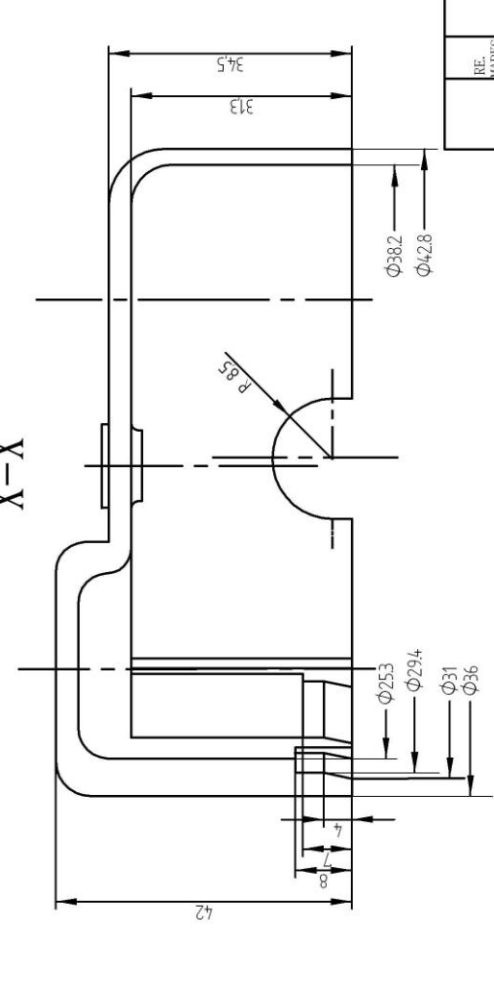
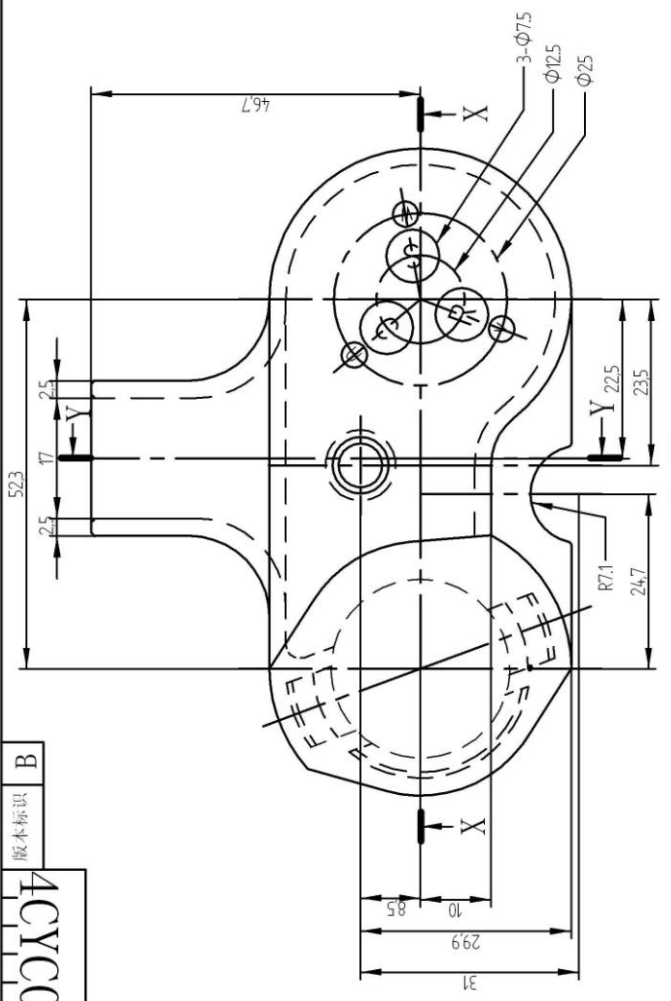

88600988

版本标识 B

MATERIAL : VALOX 420 SEO BK1066
 材 料 : 聚对苯二甲酸丁二醇脂
 DIMENSION: mm
 尺寸单 位: mm

REGD	REV. MARKS	PROJECTION	SCALE	DRAWING NO.
		第一角	NTS	4CYC00988
		Shanghai Hitachi Ltd.		
		TERMINAL-COVER		
		2016.11.3		
		2016.11.3		
		2016.11.3		

版本标识 V

4CYC01047

记号	来历	年月日	订正	审查	记号	来历	年月日	订正	审查
①					①				
②					②				
③					③				

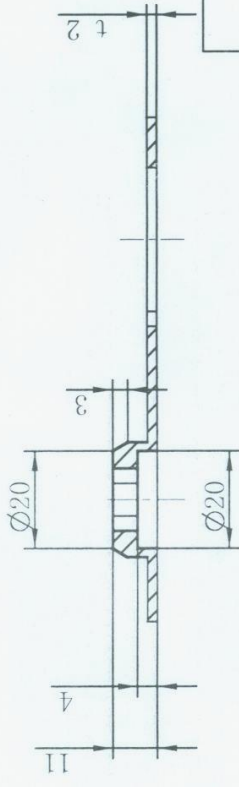
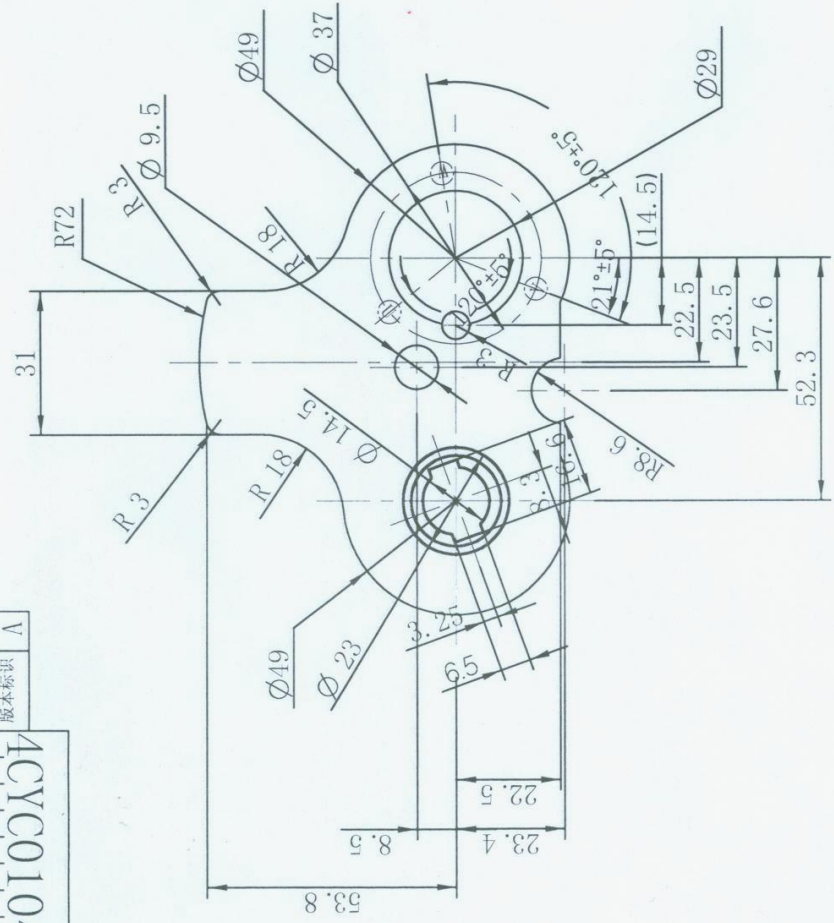

MATERIAL : EPDMFOP-B
 材 料: 三元乙丙胶
 DIMENSION: mm
 尺寸单 位: mm

REGD	RE. MARKS	SCALE	PROJECTION	SCALE
		NTS	第一角投影	NTS
DWN. 徐博	TITLE GASKET		shanghai	
CHKD. 谢飞			Hitech Ltd.	
CHKD.				
APPD. 王明				
				4CYC01047

版本标识

3CYC000004

记号	来历	年月日	订正	审查	记号	来历	年月日	订正	审查
①					④				
②					⑤				
③					⑥				

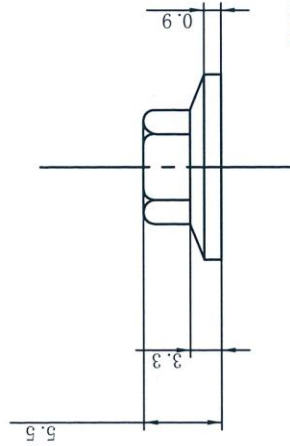
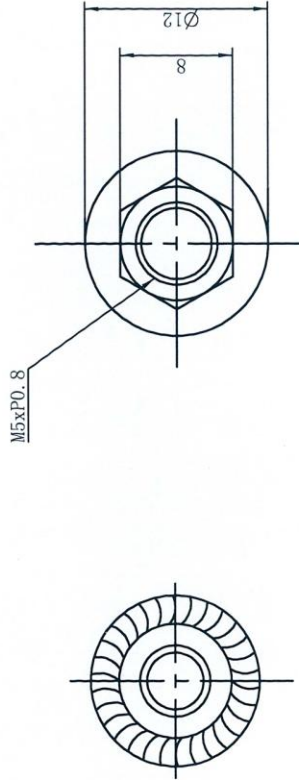

DIMENTION: mm

尺寸单位: mm

MATERIAL: 08F
 材料: 碳素结构钢

REGD	RE. MARKS	SCALE	PROJECTION	DWN NO.
		NTS		3CYC00004
			Shanghai Hitachi, Ltd.	
			TITLE	
			NUT	
			DWN.	17.3.2
			CHKD.	林国栋 17.3.3
			CHKD.	曹建刚 17.3.3
			APPD.	曹汝 17.3.3

版本标识

A

4CYC00174

记录	来历	年月日	订正	审查	记录	来历	年月日	订正	审查
①					④				
②					⑤				
③					⑥				

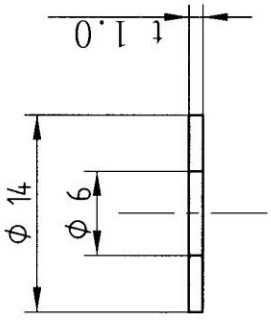
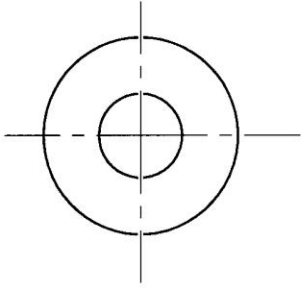

MATERIAL: EPDM
材料: 三元乙丙胶

DIMENSION: mm

REGID	RE. MARKS	PROJECTION	SCALE	DWA. NO.
		第一角	NTS	
DWA. 01.730	01.730	TITLE		
CHKD. 01.730	01.730	RUBBER WASHER		
CHKD.		Shanghai Hitachi, Ltd.		4CYC00174
APPD. 01.730				

4CYC01042
版本标识 V

记号	来历	年月日	订正	审查	记号	来历	年月日	订正	审查
①					④				
②					⑤				
③					⑥				

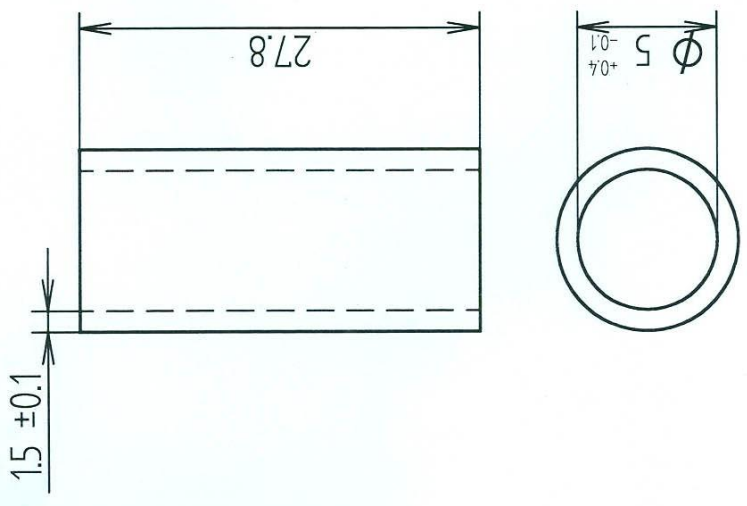

注:
 1. 颜色为白色
 2. 材质为硅橡胶

NOTE:
 1. COLOR: WHITE
 2. MATERIAL: SILICONE RUBBER

DIMENSION: mm
 尺寸单位: mm

REF. MARKS	PROJECTION		SCALE	DWN. NO.
REGD	第一角	第二角	NTS	
DWN.	TITLE		Shanghai Hitachi Ltd.	
CHKD.	12.2.1	SLEEVE	4CYC01042	
CHKD.	12.2.1			
APPD.	12.2.1			

4CYC01272

版本标识 A

记号	来历	年月日	订正	审查	记号	来历	年月日	订正	审查
①					④				
②					⑤				
③					⑥				

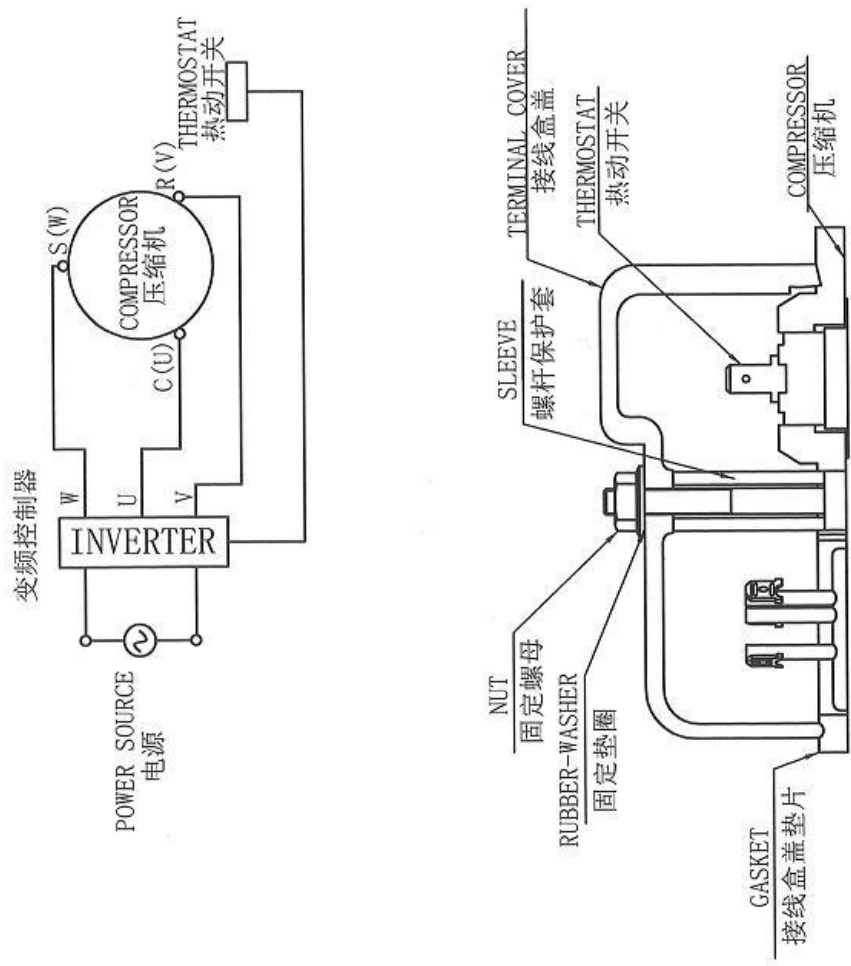
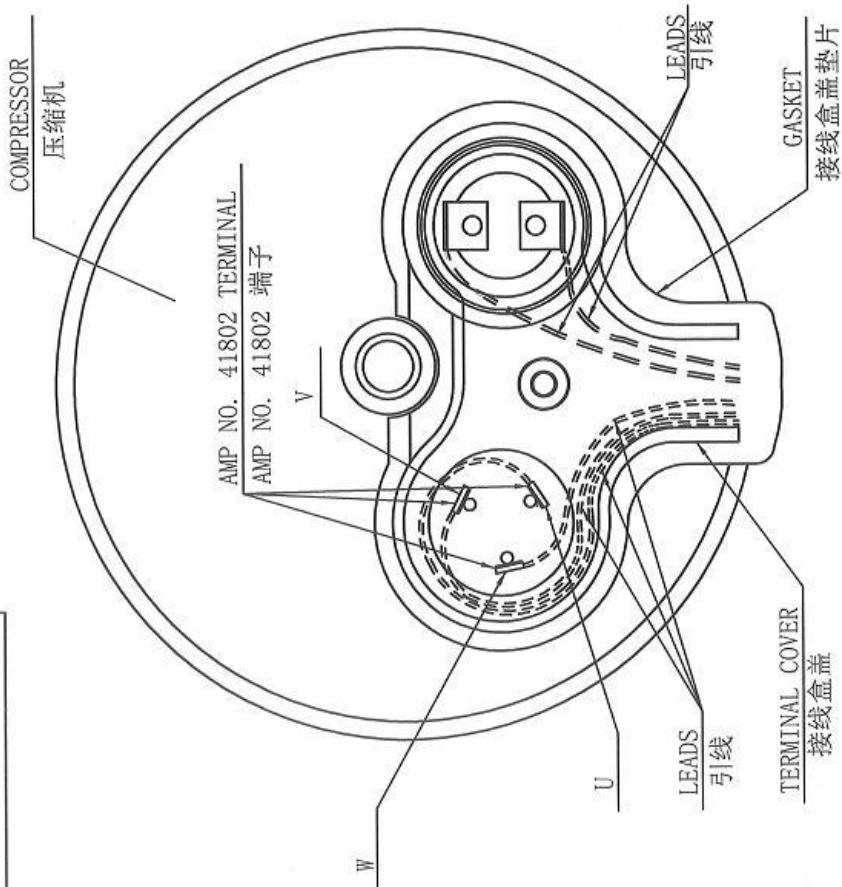

NOTES:

- PLEASE PREPARE LEADS BY YOURSELF.
- THE LETTER U, V OR W STANDS FOR EACH TERMINAL.
- TABS FOR HERMETIC TERMINAL ARE AMP #250.
- THERMOSTAT TO BE SET ON THE TOP OF COMPRESSOR AS SHOWN.

注意:

- 引线自备。
- U、V、W表示每个接线端子。
- 密封接线柱垫片为AMP NO. #250。
- 热动开关应如图放置于压缩机顶端。

REGD	RE. MARKS	TITLE		PROJECTION	SCALE	DWG. NO.
	DWN. 杨敏迪 2017.6.1	LEAD ROUTING WIRING DIAGRAM		第一角	NTS	4CYC01272
	CHKD. 杨敏迪 2017.6.1					
	CHKD. 杨敏迪 2017.6.1					
	APPL. 杨敏迪 2017.6.1					
		shanghai Hitachi Ltd.				

R410A变频热泵压缩机压力保证曲线
WHP SERIES R410A INVERTER COMPRESSOR GUARANTEE PRESSURE RANGE



图 1

CHART2 WHP DC INVERTER COMPRESSOR OIL LEVEL DATUM

图2 WHP 直流变频压缩机油面基准

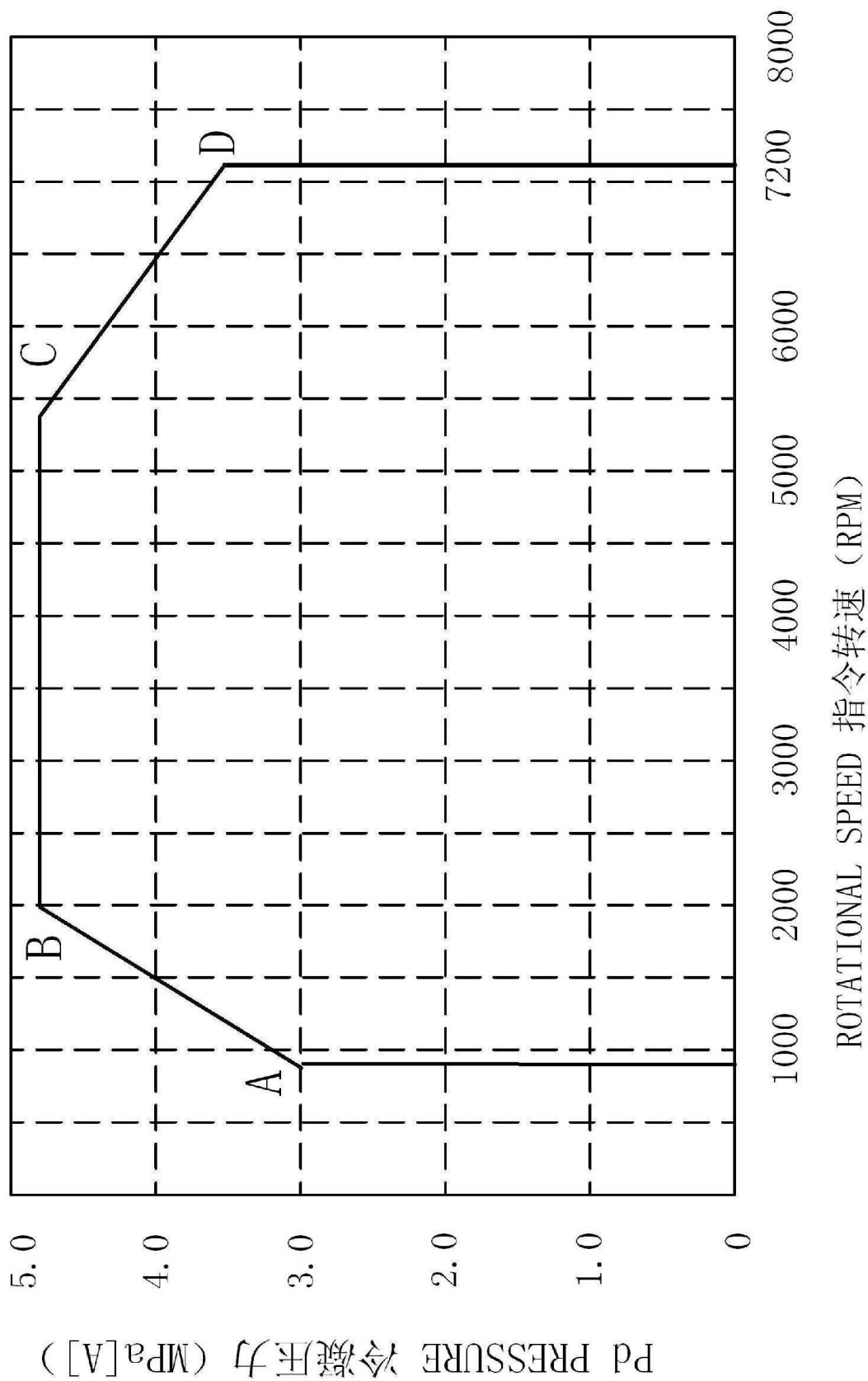

图 3 直流变频压缩机转速变化的使用说明

CHART 3 Instructions for Inverter rotary compressor revolutions change

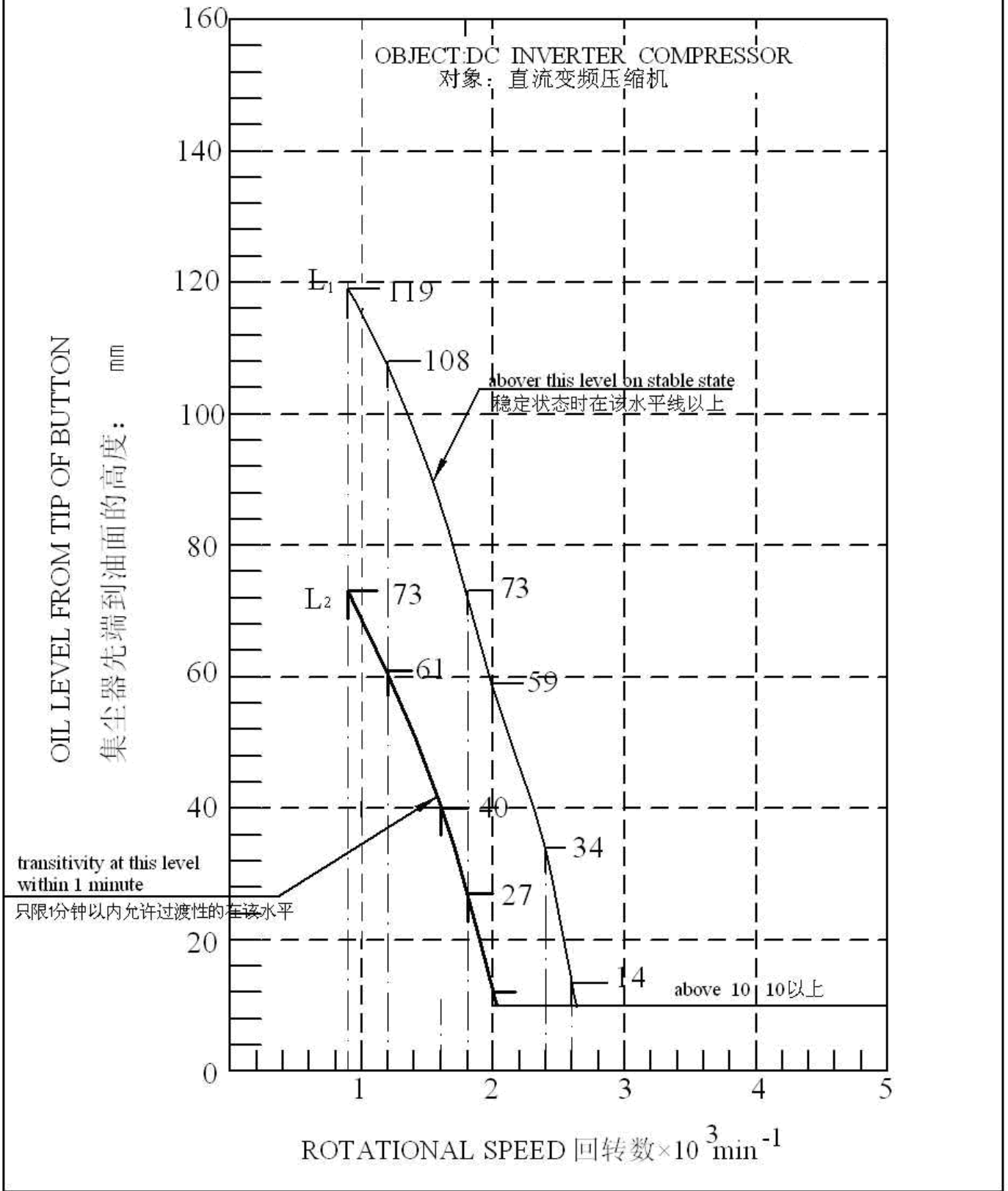
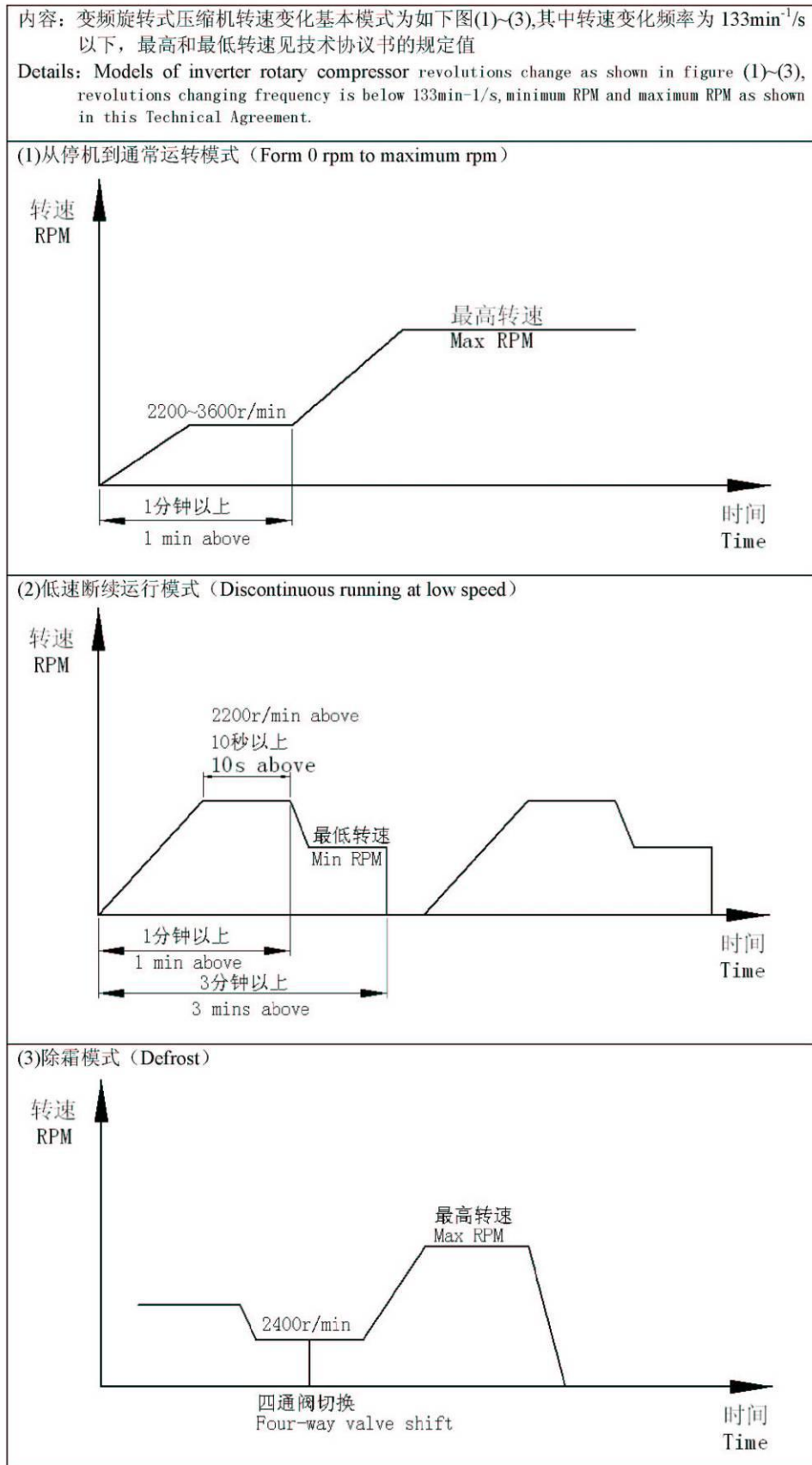

SHEC AIR CONDITIONING COMPRESSOR
WHPI1500AEDP

测定条件：冷凝温度55℃ 转速3600rpm
--EVI ON —EVI OFF

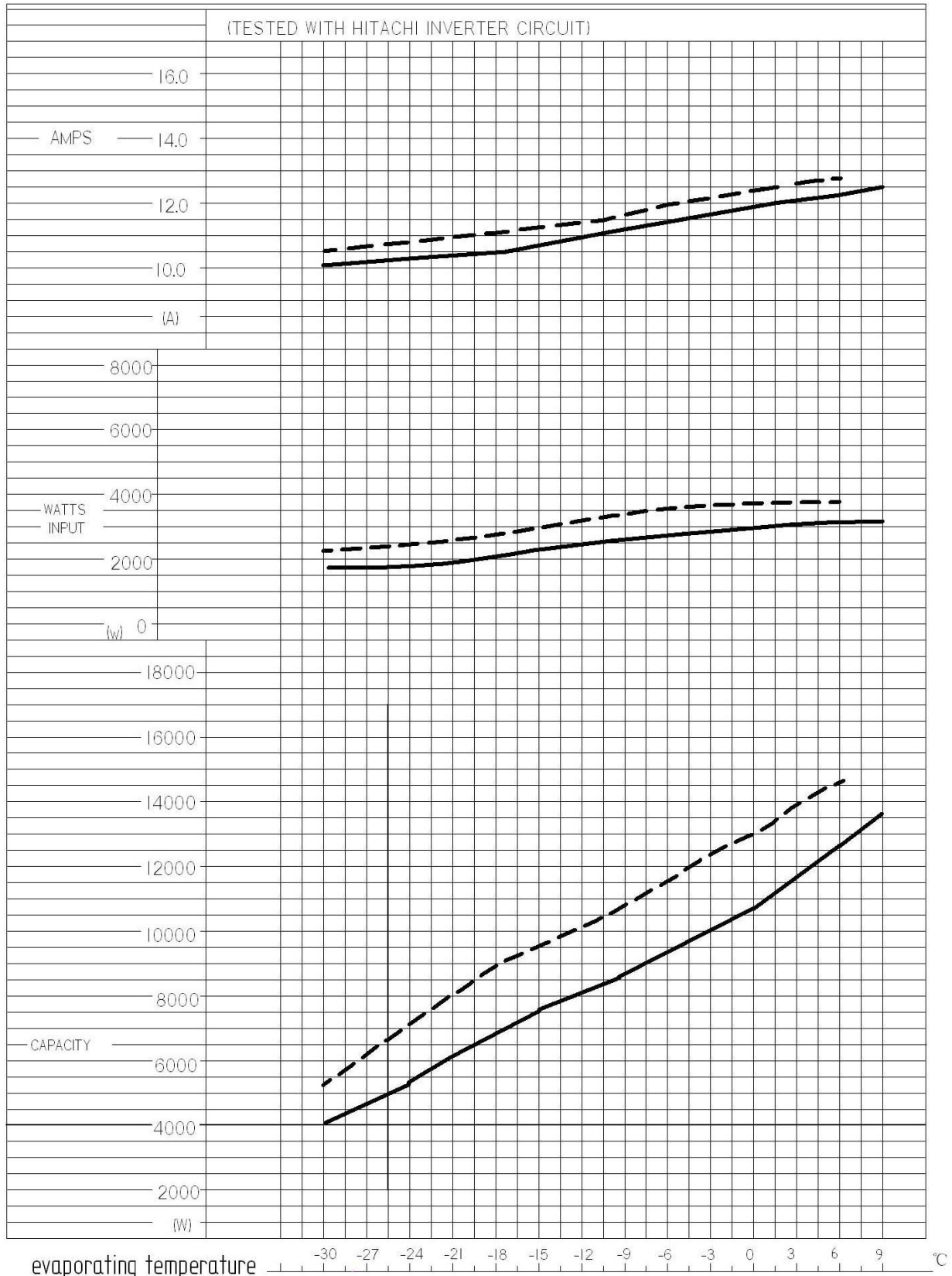

规格书修改经历 Specification Revision Record				
序号 No.	日期 Date	页码 Page in Spec	修订理由 Revision Reason	客户承认日期 Conclusion Date
A				
B				
C				
D				
E				
F				
G				
H				
J				
K				
L				
M				
N				
P				
Q				
R				
S				
U				
V				